

إحترف فن تصميم وصناعة العطور
من 4 مواد نحصل على حوالي 1187 عطر مختلف

خريطة تصميم العطور

PERFUME DESIGN MAP

CARTE DE CONCEPTION DE PARFUMS



مصمم العطور / مسعد حسن

Perfume Designer / Mossad Hassan

حقوق النشر والملكية الفكرية

إن هذا الكتاب ملكية فكرية خاصة بالمؤلف.
غير مصرح لأي شخص أو جهة بالطباعة أو النسخ أو الاقتباس منه بأي وسيلة كانت.
ومن يفعل ذلك يعرض نفسه للمساءلة القانونية.

وذلك طبقاً لقانون حماية الملكية الفكرية
رقم (82) لسنة 2002م

رقم الإيداع: 11744 / 2025
(ISBN): 978-977-95-2934-9

Copyright and Intellectual Property Rights

This book is the intellectual property of the author.
No person or entity is authorized to print, copy, or quote from it by any means whatsoever.
Anyone who does so will be legally liable.

In accordance with the Intellectual Property Protection Law
Law No. (82) of the year 2002

Deposit No.: 11744 / 2025
ISBN: 978-977-95-2934-9

Droits d'auteur et propriété intellectuelle

Ce livre est la propriété intellectuelle exclusive de l'auteur.
Aucune personne ni entité n'est autorisée à l'imprimer, le copier ou en citer des extraits, quel
que soit le moyen utilisé.
Tout contrevenant s'expose à des poursuites judiciaires.

Conformément à la loi sur la protection de la propriété intellectuelle
Loi n° 82 de l'année 2002

Dépôt légal : 11744 / 2025
ISBN : 978-977-95-2934-9



فيديو شرح للكتاب

An explanatory video of the book

Une vidéo explicative du livre

هناك كنز ملى بالجواهر. ... وهذه هي خريطة الطريق.
الكنز هو عالم العطور، و الخريطة هي خريطة تصميم العطور.
إن عالم العطور عالمٌ غامضٌ مملوءٌ بالألغاز والأسرار القيمة.
تعكس العطور على العاملين بها الجمال والمتعة والإحساس بالرفاهية، وخصوصاً مهنة تصميم العطور
إن عالم العطور مازال ينتظر التطوير والتنظيم، وذلك بعد ظهور التكنولوجيا الحديثة.
وما زالت البشرية على أعتاب هذا العلم، ومن يكتشف من هذا العلم شيئاً يعد من العظماء.
إن مجال العطور يجمع بين الفن والعلم، كما يرتبط بمجالات كثيرة مثل علم النفس والسلوك
ووظائف الأعضاء، والكيمياء، والنبات والفن والجيولوجيا والتحاليل.
(كيمياء العطور) شارلز سيل

There is a treasure filled with jewels.... and this is the roadmap.

The treasure is the world of perfumes, and the map is the perfume design map.

The world of perfumes is a mysterious world full of puzzles and valuable secrets

Perfumes reflect beauty, pleasure, and a sense of luxury on those who work with them, especially in the profession of perfume design.

The world of perfumes is still awaiting development and organization, after the emergence of modern technology.

And humanity is still on the verge of this science, and whoever discovers something from this science is considered one of the greats.

The field of perfumes combines art and science, and it is also related to many fields such as psychology, behavior, organ functions, chemistry, botany, art, geology, and analysis.

(THE CHEMISTRY OF FRAGRANCES) CHARLES SELL

Il y a un trésor rempli de bijoux et voici la feuille de route.

Le trésor est le monde des parfums, et la carte est la carte de conception de parfum.

Le monde des parfums est un monde mystérieux plein d'énigmes et de précieux secrets.

Les parfums reflètent la beauté, le plaisir et la sensation de bien-être pour ceux qui y travaillent, et en particulier pour le métier de concepteur de parfums.

Le monde des parfums attend encore son développement et son organisation, après l'émergence des technologies modernes.

Et l'humanité est encore au bord de cette science, et celui qui découvre quelque chose de cette science est considéré comme l'un des grands.

Le domaine des parfums allie l'art et la science, et il est également lié à de nombreux domaines tels que la psychologie, le comportement, les fonctions organiques, la chimie, la botanique, l'art, la géologie et l'analyse.

(LA CHIMIE DES PARFUMS) CHARLES SELL

الكل يتعاون ويعمل كفريق.

إنَّ عالمَ العطور ينتظر كل مجتهد ليكتب اسمه حتى وإن كان تلميذاً صغيراً مثلي.

أحببت أن أقدم هذا العمل المتواضع البسيط إلى كل العاملين والمحبين وأساتذتي من مصممي العطور في العالم، ليكون لهم مساعدا ومرشداً.

إنَّ عالمَ تصميم العطور بالرغم من أنه أكثر المهن متعة إلا أنه ظل عملاً صعباً وشاقاً وليس بالسهل، حيث أن هذه مهنتي (مصمم للعطور).

استخدمت علم الإحصاء لتسهيل المهمة. فأنشأت خريطة تصميم العطور.

كنت وما زلت أتعلم ويرجع الفضل لمطوري علم العطور في العصر الحديث، وهم المجددون والعلماء الذين تعلمت منهم.

مؤسس شركة بيرفيومرز وورلد (الاسطورة/ستيفن)

د. لوقا تورين. د. جانسر أولف. ويلهلم بيكنهاجن. د. فيليب كرافت
جان كلود إيلينا.

Everyone cooperates and works as a team.

The world of perfumes awaits every hardworking person to write their name, even if they are a small student like me

I wanted to present this humble and simple work to all the workers, lovers, and my teachers, the perfume designers in the world, to be a helper and a guide for them

Although the world of perfume design is one of the most enjoyable professions, it remains a difficult and arduous task, and it is not easy. Since this is my profession (perfume designer)

I used statistics to facilitate the task. So I created the perfume design map

I was and still am learning, and the credit goes to the developers of perfume science in the modern era, who are the innovators and scientists from whom I learned.

* Founder of Perfumers World: MR. STEPHEN / the legend

DR . LUCA TURIN - DR. GUNTHER OHLFF. WILHELM PICKENHAGEN - PHILIP KRAFT
JEAN CLAUDE ELLENA

Tout le monde coopère et travaille en équipe.

Le monde du parfum attend que chaque personne travailleuse y inscrive son nom, même si c'est un petit étudiant comme moi.

Je voulais présenter ce travail humble et simple à tous les travailleurs, les amoureux, et mes professeurs, les créateurs de parfums du monde entier, pour qu'il leur soit une aide et un guide.

Bien que le monde du design de parfums soit l'une des professions les plus agréables, il reste un travail difficile et ardu, et ce n'est pas facile. Car c'est mon métier (créateur de parfums)

J'ai utilisé les statistiques pour faciliter la tâche. J'ai donc créé la carte de conception de parfum.

J'étais et je suis toujours en apprentissage, et le mérite revient aux développeurs de la science du parfum à l'ère moderne, qui sont les innovateurs et les scientifiques auprès desquels j'ai appris.

*Fondateur de Perfumers World : M. STEPHEN / la légende

DR. LUCA TURIN - DR. GUNTHER OHLFF. WILHELM PICKENHAGEN - PHILIP KRAFT.
JEAN CLAUDE ELLENA

وإيماناً واقتناعاً منى أن التلميذ قد يبدع ويتفوق ويقدم إنجازات.

** من اليوم لن يكون تصميم العطور أمراً صعباً.

تساعدنا الخريطة من الحصول على حوالي 1187 عطر مختلف من 4 عطور فقط، ولن يستغرق الأمر إلا ساعات معدودة.

إن العطور هي السر الغامض الذي يؤثر على الإنسان حيث تتفاعل ذرات العطر بعد تحولها لإشارات كهربائية مع الطبقات العليا من الجهاز العصبي المركزي، و تؤثر على النفس والسلوك والعاطفة.

حيث تقع البصيلة الشمية وهي (مركز حاسة الشم) بجوار مركز الذاكرة والعاطفة.

And with faith and conviction, I believe that the student may be creative, excel, and make achievements.

From today, designing perfumes will not be difficult.

The map helps us to get about 1187 different perfumes from only 4 perfumes, and it will only take a few hours.

Perfumes are the mysterious secret that affects humans, as the perfume atoms, after converting into electrical signals, interact with the upper layers of the central nervous system, and affect the psyche, behavior, and emotions.

Where the olfactory bulb (the center of smell) is located next to the center of memory and emotion.

Et avec foi et conviction, je crois que l'élève peut être créatif, exceller et faire des réalisations.

À partir d'aujourd'hui, concevoir des parfums ne sera plus difficile.

La carte nous aide à obtenir environ 1187 parfums différents à partir de seulement 4 parfums, et cela ne prendra que quelques heures.

Les parfums sont le mystérieux secret qui affecte les humains, car les atomes de parfum, après s'être convertis en signaux électriques, interagissent avec les couches supérieures du système nerveux central et affectent le psychisme, le comportement et les émotions.

Là où le bulbe olfactif (le centre de l'odorat) est situé à côté du centre de la mémoire et des émotions.

منذ فترة قصيرة لم تتوصل البشرية إلى تفسير حاسة الشم، وذلك لأن الأمر يتعلق بالكشف عن كهربية المخ، ومع التطور الحديث في الأجهزة والتقنيات أصبح علماء التشريح ووظائف الأعضاء قادرين على تفسير آلية عمل حاسة الشم، وإثبات العلاقة القوية بين جزيئات العطر وحالة الإنسان العضوية والنفسية.

متخصصة وظائف الأعضاء/ أنا تشارشل، (كيمياء العطور).

وأن هذا كتابي القادم، (تأثير العطور على النفس والسلوك والعاطفة)

ويعد هذا الكتاب الانطلاقة الأولى للعصر الثالث للعطور، وهي العطور المؤثرة على النفس والسلوك والعاطفة (عطور المستقبل).

A short time ago, humanity did not have an explanation for the sense of smell, because it is related to the detection of brain electricity.

With recent developments in devices and technologies, anatomists and physiologists have become able to explain the mechanism of the sense of smell, and prove the strong relationship between fragrance molecules and the organic and psychological state of a human being.

PSYCHOLOGICAL.

ANNE CHURCHILL

THE CHEMISTRY OF FRAGRANCES

And this is my next book, (The Effect of Fragrances on the Psyche, Behavior, and Emotion)

This book is considered the first launch of the third era of perfumes, which are perfumes that affect the psyche, behavior, and emotions. (perfumes of the future).

Il n'y a pas si longtemps, l'humanité n'était pas parvenue à expliquer le sens de l'odorat, car il s'agit de détecter l'activité électrique du cerveau. Avec les récents progrès des appareils et des technologies, les anatomistes et les physiologistes ont pu expliquer le mécanisme du sens de l'odorat et prouver le lien étroit entre les molécules de parfum et l'état organique et psychologique de l'homme.

PSYCHOLOGICAL

ANNE CHURCHILL

THE CHEMISTRY OF FRAGRANCES

Et voici mon prochain livre, (L'influence des parfums sur le psychisme, le comportement et les émotions)

Ce livre est considéré comme le premier lancement de la troisième ère des parfums, qui sont des parfums qui affectent le psychisme, le comportement et les émotions. (parfums du futur)

من يرى أى أخطاء، أو أى ملاحظات لا يتردد فى إرسالها

صفحة فيس بوك: خريطة تصميم العطور Perfume Design Map

إيميل: mossad@perfumersacademy.com

أو الموقع الإلكتروني: www.Perfumersacademy.com

00201274264406

00201064320042

مصمم العطور / مسعد حسن

مؤسس أكاديمية صناع العطور

Any errors or any notes, do not hesitate to send them

Facebook page: Perfume Design Map خريطة تصميم العطور

Email: mossad@perfumersacademy.com

Or the website www.Perfumersacademy.com

00201274264406

00201064320042

Perfume Designer / Mossad Hassan

Founder of Perfumers Academy

Qui voit des erreurs ou des remarques, n'hésitez pas à les envoyer

Page Facebook : Perfume Design Map خريطة تصميم العطور

E-mail : mossad@perfumersacademy.com

Ou site Web : www.Perfumersacademy.com

00201274264406

00201064320042

Créateur de Parfum / Mossad Hassan

Fondateur de Perfumers Academy

العطور .. من أين؟؟ - وإلى أين؟؟؟

قصة العطر.....

عاش الإنسان مستكشفاً للطبيعة وظل العطر محبوباً في زهرته .

ظل العطر يستميل رغبة الإنسان عبر حاسة الشم وغريزته المحبة لاستكشاف ما ينفعه ويحتاج اليه.

الإنسان... ذلك الكائن الحي الذي يتكون من 30 إلى 37 تريليون خلية تتنوع إلى 200 نوع لتكون باقي أجهزة الجسم، تسيطر عليه الحواس الخمس وهي أذرع المخ التي يعتمد عليها في اتخاذ قراراته، السمع والبصر واللمس والتذوق والشم، منهم حاستي التذوق والشم التي يطلق عليها الحواس الكيميائية التي تعتمد على التفاعلات الكيميائية بين المحيط الخارجي واللعباب في الفم والمستقبلات الشمية في الأنف.

(علم التشريح ووظائف الأعضاء والكيمياء الحيوية لمستقبلات الشم)، جانثر أولف

Perfumes.. .. Where from?? - And where to???

The story of perfume.....

Man lived exploring nature, and the perfume remained imprisoned in its flower.

The perfume continued to entice man's desire through the sense of smell and his instinct to explore what benefits him and what he needs.

Man... that living being that consists of 30 to 37 trillion cells, diversifying into 200 types to form the rest of the body's organs, is controlled by the five senses, which are the arms of the brain that he relies on in making his decisions.

Hearing, sight, touch, taste, and smell, including the senses of taste and smell, which are called chemical senses that depend on chemical reactions between the external environment and saliva in the mouth and olfactory receptors in the nose.

ANATOMY, PHYSIOLOGY, AND BIOCHEMISTRY OF OLFACATORY RECEPTORS. GUNTHER OHLFF

Les parfums... d'où viennent-ils ? Et où vont-ils ???

L'histoire du parfum.....

L'homme a vécu en explorant la nature et le parfum est resté prisonnier de sa fleur.

Le parfum a continué à séduire le désir de l'homme par le sens de l'odorat et son instinct amoureux d'explorer ce qui lui est utile et dont il a besoin.

L'homme... cet être vivant composé de 30 à 37 billions de cellules, se diversifiant en 200 types pour former le reste des organes du corps, est contrôlé par les cinq sens, qui sont les bras du cerveau sur lesquels il s'appuie pour prendre ses décisions.

L'ouïe, la vue, le toucher, le goût et l'odorat, parmi lesquels le goût et l'odorat sont appelés sens chimiques, qui dépendent des réactions chimiques entre l'environnement extérieur, la salive dans la bouche et les récepteurs olfactifs dans le nez.

ANATOMIE, PHYSIOLOGIE ET BIOCHIMIE DES RÉCEPTEURS OLFACATIFS. GUNTHER OHLFF

حياة الإنسان

تنحصر حياة الإنسان بين شئنين الرغبة والمعاناة، رغبة الإنسان في أن يعيش في الدنيا مستمتعا بها، يلجأ إلى الطعام والشراب والحياة الاجتماعية، والمعاناة من المرض والموت والحر والبرد والتشرد. تلتقط الحواس ما قد تهلك حياة الإنسان وتسبب له المتاعب والآلام، ثم تأتي الزهور برائححتها الخلابه لترسل للإنسان رسالة احتواء، وطمانينة، تذهبه إلى عالم آخر وتنقله إلى الرفاهية وعالم الجمال والمتعة، كان الإنسان يلجأ للزهور الجميلة ليلتمس عطرها، وازداد جمال العطر في عينيه كلما نظر إلى جمال القالب الذي يقدم فيه، وهى الورود بألوانها الخلابه، كان يقطف الورد ويحملها معه إلى بيته وإلى معبده وإلى أحبائه، فارتبطت العطور منذ عهدنا الأول بالمناسبات السعيدة، حيث كانت ترمز إلى الأحاسيس الجميلة والمهمة منها العبادة والتقديس، والعلاقات العاطفية بين الرجل والمرأة.

Human life

Human life is confined between two things: desire and suffering. Man's desire to live in the world enjoying it

He resorts to food, drink, and social life, and suffers from illness, death, heat, cold, and homelessness.

The senses capture what may destroy human life and cause him troubles and pains, then flowers come with their wonderful scent to send a message of containment and reassurance to humans, taking him to another world and transporting him to luxury and the world of beauty and pleasure.

Man used to resort to beautiful flowers to seek their fragrance, and the beauty of the fragrance increased in his eyes whenever he looked at the beauty of the mold in which it is presented, which are roses with their beautiful colors.

He used to pick the rose and carry it with him to his home, to his temple, and to his loved ones, so perfumes have been associated since their early days with happy occasions, as they symbolized beautiful and important feelings, including worship and sanctification, and emotional relationships between men and women.

La vie humaine

La vie de l'homme se résume à deux choses : le désir et la souffrance. Le désir de l'homme de vivre dans ce monde et d'en jouir,

il recourt à la nourriture, à la boisson et à la vie sociale, et la souffrance de la maladie, de la mort, de la chaleur, du froid et de l'errance.

Les sens captent ce qui peut détruire la vie de l'homme et lui causer des ennuis et des douleurs, puis viennent les fleurs avec leur parfum enchanteur pour envoyer à l'homme un message de réconfort et de tranquillité, l'emportant dans un autre monde et le transportant vers le bien-être et le monde de la beauté et du plaisir,

L'homme avait recours aux belles fleurs pour implorer leur parfum, et la beauté du parfum augmentait à ses yeux à mesure qu'il regardait la beauté du moule dans lequel il était présenté, à savoir les roses aux couleurs éclatantes.

Il cueillait la rose et l'emportait avec lui chez lui, dans son temple et auprès de ses proches. Les parfums ont donc été associés, dès leurs débuts, aux occasions heureuses, où ils symbolisaient les beaux sentiments et les plus importants d'entre eux, comme le culte et la vénération, et les relations amoureuses entre l'homme et la femme.

كان الإنسان يستعمل الزهور للتطيب، بالطحن، ثم يدهنها على جسده أو ثيابه وبالحرق أيضاً، ومنها جاءت كلمة PERFUME من اللاتينية PER FUMUM وتعنى عبر الدخان.

كان الإنسان يتمتع بالورود ويأخذها إلى بيته ليرتشف من عطرها الذكي ولكن ماهي إلا أيام فتذبل الوردة وتموت ويموت معها عبيرها.

ظل الإنسان آلاف السنين يبحث عن الإلهام والإلهام يبحث عنه، ظل ينظر إلى الورود وعطرها التي بداخلها، وكأنه يسمع صوتاً خافتاً يأتي من داخل الوردة، وكأنه صوت سجين محبوس بالداخل، إنه صوت العطر، وكأنه ينادي عليه أن يحرره من الداخل ليتجول معه في أي مكان.

ظل الإنسان واقفاً لا يدري الكيفية التي سيستخرج بها العطر من الداخل، حيث أن ذرات العطر تتطاير مع ارتفاع درجة الحرارة، فالنباتات عندما يتم غليها في الماء، تتطاير ذرات العطر مع بخار الماء، ولكن كيف يتم جمع ذرات العطر المتطايرة مع بخار الماء مرة أخرى، وجد أن العامل أيضا هو خفض درجة الحرارة، وكانت فكرة عمل (المكثف).

Man used flowers for fragrance, by grinding, then anointing them on his body or clothes, and also burning, and from this came the word PERFUME from the Latin PER FUMUM, meaning through smoke.

Man used to enjoy roses and take them to his home to inhale their smart fragrance, but within days, the rose would wither and die, and its fragrance would die with it.

For thousands of years, man kept searching for inspiration, and inspiration kept searching for him. He kept looking at the roses and the fragrance within them, as if he heard a faint voice coming from inside the rose, like the voice of a prisoner trapped inside. It was the voice of the fragrance, as if it was calling him to free it from within to roam with him anywhere.

A man stood still, not knowing how to extract the perfume from within, as the perfume particles evaporate with rising temperatures. When plants are boiled in water, the perfume particles evaporate with the water vapor. But how can the perfume particles that have evaporated with the water vapor be collected again? He found that the solution was also to lower the temperature, and that was the idea behind "the condenser".

L'homme utilisait les fleurs pour se parfumer, en les broyant, puis en les appliquant sur son corps ou ses vêtements, et aussi en les brûlant, d'où le mot PERFUME, du latin PER FUMUM, qui signifie à travers la fumée

L'homme appréciait les roses et les rapportait chez lui pour respirer leur parfum intelligent. Mais en quelques jours seulement, la rose fane et meurt, et son parfum meurt avec elle.

Pendant des milliers d'années, l'homme a cherché l'inspiration et l'inspiration l'a cherché. Il a continué à regarder les roses et leur parfum à l'intérieur, comme s'il entendait une faible voix venant de l'intérieur de la rose, comme la voix d'un prisonnier enfermé à l'intérieur. C'est la voix du parfum, comme s'il l'appelait pour le libérer de l'intérieur afin qu'il puisse se promener avec lui n'importe où.

L'homme resta debout, ne sachant pas comment extraire le parfum de l'intérieur, car les particules de parfum s'évaporent avec l'augmentation de la température. Lorsque les plantes sont bouillies dans l'eau, les particules de parfum s'évaporent avec la vapeur d'eau, mais comment collecter à nouveau les particules de parfum volatiles avec la vapeur d'eau ? Il a découvert que le facteur était également l'abaissement de la température, et l'idée était de créer "un condenseur".

لحظات !!! وجابر بن حيان يطرق باب المعرفة، ليفتح له الطريق ويخطو أولى الخطوات في وجود العطور في حياة البشرية، أخيراً !!! جاء من البشر من استطاع أن يحرر العطر من محبسه، أخيراً !!! سيتجول العطر معنا أينما نكون في زجاجة صغيرة يسافر بين البلاد.

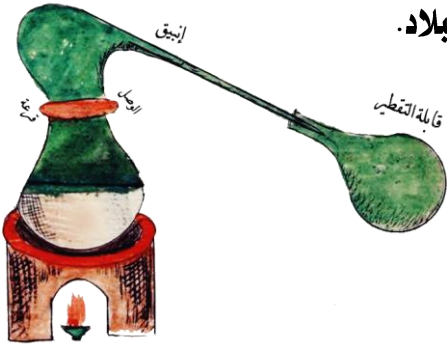

أخيراً !!! أصبح العطر رداءً يرتديه من يهواه، أصبح العطر حراً طليقاً يتجول في عالم البشر، ليؤدي دوره في الحياة، عن طريق اختراعه لجهاز الأنبيق أو الأمبيق (721م - 815م).

ثم قام الرازي (866م - 921م) و ابن سينا (980م - 1037م)

بتطوير طرق التقطير، وسرعان ما انتشرت أجهزة التقطير وكان عصرًا فريدًا، ومنذ ذلك التاريخ إلى الآن أصبحت أوروبا وخصوصًا فرنسا وبالأخص جنوبها مدينة "جراس"، عاصمة العطور في العصر الحديث.

فرح الإنسان بوجود العطر وسرعان ما انتشرت مهنة صانع العطر، بالخلط والعزل وولد علم كيمياء العطور بعزل المركبات وخلطها، وفن الزجاج والكحول، ولكن ظل العطر مقتصرًا على الطبقات الثرية، حيث من مليون وردة نحصل على كيلو زيت، ومن 7 مليون زهرة ياسمين نحصل على كيلو زيت.

Moments and Jabir ibn Hayyan knocks on the door of knowledge, opening the way for him to take the first steps in the existence of perfumes in human life. Finally!!!, someone came from among humans who was able to free the perfume from its confinement. Finally!!!, perfume will roam with us wherever we are in a small bottle, traveling between countries. Finally!!!, perfume has become a garment worn by those who love it. Perfume has become free, roaming the world of humans, playing its role in life, through his invention of the alembic or still (721 AD - 815 AD).

Then Al-Razi (921 AD - 866 AD) and Ibn Sina (980 AD - 1037 AD) developed distillation methods, and distillation devices quickly spread. It was a unique era, and from that date until now, Europe, especially France, and particularly its south, the city of Grasse, has become the capital of perfumes in the modern world.

Humans rejoiced in the existence of perfume, and the profession of perfumer quickly spread, through mixing and isolation, and the science of perfume chemistry was born by isolating and mixing compounds, and the art of glass and alcohol. However, perfume remained limited to the wealthy classes, as from a million roses we get a kilo of oil, and from 7 million jasmine flowers we get a kilo of oil.

Moments et Jabir Ibn Hayyan frappe à la porte de la connaissance, pour lui ouvrir la voie et faire les premiers pas dans l'existence des parfums dans la vie de l'humanité. Enfin!!!, parmi les humains, quelqu'un a réussi à libérer le parfum de sa prison. Enfin!!!, le parfum se promènera avec nous où que nous soyons, dans une petite bouteille voyageant entre les pays. Enfin!!!, le parfum est devenu un vêtement porté par ceux qui l'aiment. Le parfum est devenu libre, errant dans le monde des humains, jouant son rôle dans la vie, grâce à son invention de l'alambic, entre 721 et 815 après J.-C.

Ensuite, Al-Razi (866-921 après J.-C.) et Ibn Sina (980-1037 après J.-C.) ont développé les méthodes de distillation, et les appareils de distillation se sont rapidement répandus. Ce fut une époque unique. Et depuis lors, l'Europe, et en particulier la France, notamment son sud, la ville de Grasse, est devenue la capitale du parfum dans le monde moderne.

L'homme s'est réjoui de l'existence du parfum et le métier de parfumeur s'est rapidement répandu, par le mélange et l'isolement. La science de la chimie des parfums est née en isolant et en mélangeant des composés, ainsi que l'art du verre et de l'alcool. Cependant, le parfum est resté limité aux classes riches, car d'un million de roses, on obtient un kilo d'huile, et de 7 millions de fleurs de jasmin, on obtient un kilo d'huile.

العصر الثاني

كيف انتشرت العطور الى جميع الطبقات؟

أخرجت الأرض كنزاً مدفوناً هو البترول. حصل الإنسان على الأطنان من الزيوت العطرية بأرخص الأثمان واليوم وصل العطر للجميع. في بدايات القرن التاسع عشر. وازدهرت العطور وانتشرت بيوت الازياء والعبوات الجميلة.

لم تخلو اهتمامات الأدباء والمؤرخين والفلاسفة من الاهتمام بالعطور. منذ أول مخطوطة لتاريخ البشرية 3200 ق.م. مروراً بأرسطو الذي قال: (إن الروائح الطيبة تساعد في رفاهية البشرية) ومؤسس نظرية الشم (تيتيوس ليكريتيوس 90 ق.م). ومطوري عالم العطور في العهد الحديث، مثل: جابريل كوكو شانيل، وفرانسوا كوتي، وجيرلان وجان بول جوتيه، وجان كلود ايلينا، وروجا دوف، وديلفين آرنولد.

The Second Age

How did perfumes spread to all classes?

The earth brought forth a buried treasure, which is petroleum. Humans obtained tons of essential oils at the cheapest prices, and today perfume has reached everyone. In the early 19th century, Perfumes flourished and fashion houses spread, and beautiful bottles. The interests of writers, historians, and philosophers have not been devoid of interest in perfumes, since the first manuscript of human history 3200 BC, through Aristotle, who said: (Good smells help in the well-being of humanity).

And the founder of the theory of smell, Titus Lucretius 90 BC.

And developers of the world of perfumes in the modern era, such as: Gabrielle Coco Chanel, and François Coty, Guerlain, Jean Paul Gaultier, Jean-Claude Ellena, Roja Dove, and Delphine Arnould.

Le deuxième âge

Comment les parfums se sont-ils répandus dans toutes les classes sociales?

La terre a révélé un trésor enfoui : le pétrole. L'homme a obtenu des tonnes d'huiles essentielles à des prix très bas et, aujourd'hui, le parfum est accessible à tous. Au début du XIXe siècle,

Les parfums ont prospéré, les maisons de couture se sont multipliées et les beaux flacons n'ont pas échappé à l'attention des écrivains, des historiens et des philosophes. Depuis le premier manuscrit de l'histoire de l'humanité en 3200 avant J.-C., en passant par Aristote qui a dit : « Les bonnes odeurs contribuent au bien-être de l'humanité.»

Et le fondateur de la théorie de l'odorat, Titus Lucretius 90 avant J.-C. jusqu'aux développeurs du monde du parfum dans l'ère moderne, tels que Gabrielle Coco Chanel.

François Coty, Guerlain, Jean Paul Gaultier, Jean-Claude Ellena, Roja Dove et Delphine Arnould

إعتاد الإنسان في العصر الحديث أن يرى العطور مرتبطة بالهوا واللعب، والكماليات والزينة والجاذبية والعلاقة الرومانسية بين الرجل والمرأة.

ولكن اكتشف العلماء من تخصصات الطب النفسي والسلوكي ووظائف الأعضاء أن العطور أكثر أهمية من ذلك بكثير، وخصوصا أن المركبات العطرية لها تأثير علاجي على النفس والسلوك والشفاء من كثير من الأمراض، ويعتقد العلماء أن حاسة الشم هي أكثر الحواس غموضا و تعقيدا وأهمها على الإطلاق، وذلك لارتباط مركز حاسة الشم (البصيلة الشمية) مع الجهاز الحوفي حيث مركز العاطفة ولها القدرة فوق كل الحواس حيث في لحظة تنقلنا في عالم آخر وزمان آخر عبر الذكريات أو التغافل في نفسيتنا للتأثير على الحالة المزاجية للإنسان.

كيمياء العطور (ديفيد بيبوس)

Modern man is used to seeing perfumes associated with fun and games, luxuries, adornments, attractiveness, and the romantic relationship between men and women.

But scientists specializing in psychology, behavior, and physiology have discovered that perfumes are much more important than that, especially since aromatic compounds have a therapeutic effect on the psyche, behavior, and healing from many diseases. Scientists believe that the sense of smell is the most mysterious, complex, and most important of all senses.

This is because the center of the sense of smell (the olfactory bulb) is connected to the limbic system, which is the center of emotion, and it has the ability, above all other senses, to transport us in a moment to another world and another time through memories or to penetrate our psyche to influence the human mood.

DAVID PYBUS (CHEMISTRY OF FRAGRANCES).

L'être humain à l'ère moderne est habitué à associer les parfums au divertissement, aux loisirs, au luxe, à la parure, à l'attractivité et aux relations romantiques entre hommes et femmes.

Cependant, les scientifiques spécialisés en psychiatrie, en psychologie comportementale et en physiologie ont découvert que les parfums sont bien plus importants que cela, en particulier parce que les composés aromatiques ont un effet thérapeutique sur le psychisme, le comportement et la guérison de nombreuses maladies. Les scientifiques pensent que l'odorat est le sens le plus mystérieux, le plus complexe et le plus important de tous.

Cela est dû au lien entre le centre de l'odorat (le bulbe olfactif) et le système limbique, où se trouve le centre des émotions. L'odorat a le pouvoir, au-delà de tous les autres sens, de nous transporter instantanément dans un autre monde et un autre temps à travers les souvenirs, ou de pénétrer notre psychisme pour influencer l'humeur humaine.

DAVID PYBUS (CHEMISTRY OF FRAGRANCES)

عصر جديد من عصور تطور استعمال العطر.

A new era in the development of perfume use.

Une nouvelle ère dans le développement de l'utilisation du parfum.

العطور المؤثرة

و تنقسم إلى قسمين المحفزة والمعالجة:

مع تطور العلم استطاع العلماء الكشف عن تأثير الإنسان بالروائح وتأثير العطور على الجهاز العصبي للإنسان وحركه خلايا المخ، ومع تطور الفكر البشري للنظر إلى العطور نظرة أكثر أهمية وهي العلاج بالعطور. كان لزاماً أن يبدأ عصر جديد من عصور تطور الجنس البشري لاستعمال العطور. تأخرت زجاجة العطر كثيراً في سباق التطور.

منذ آلاف السنين لم تتغير ربما أن الأوان للتحرر مرة أخرى. وهو بداية العصر الثالث للعطور.

مسعد حسن

Influential perfumes

And are divided into two parts: stimulants and treatments

With the development of science, scientists were able to reveal the effect of scents on humans and the effect of perfumes on the human nervous system and the movement of brain cells, and with the development of human thought to look at perfumes with a more important view, which is treatment with perfumes, it was necessary to start a new era of human development to use perfumes.

The perfume bottle has been delayed a lot in the development race.

For thousands of years, it has not changed, perhaps it is time to break free again. It is the beginning of the third era of perfumes.

MOSSAD HASSAN

Les parfums influents

Et ils sont divisés en deux parties : stimulants et thérapeutiques.

Avec le développement de la science, les scientifiques ont pu découvrir l'influence des odeurs sur l'homme et l'effet des parfums sur le système nerveux humain et le mouvement des cellules cérébrales. Avec l'évolution de la pensée humaine pour considérer les parfums avec plus d'importance, à savoir l'aromathérapie, il était nécessaire de commencer une nouvelle ère dans l'évolution de l'espèce humaine pour l'utilisation des parfums.

Le flacon de parfum a pris beaucoup de retard dans la course à l'évolution.

Depuis des milliers d'années, il n'a pas changé, il est peut-être temps de se libérer à nouveau. C'est le début de la troisième ère du parfum.

Mossad Hassan

العائلات العطرية

Fragrant Families

Les familles olfactives

تنقسم العائلات العطرية إلى 5 عائلات مختلفة فإذا قمنا بوضع رمز لكل عائلة، كالمثال التالي:-

The aromatic families are divided into 5 different families, so if we put a symbol for each family. like the following example:-

Les familles aromatiques sont divisées en 5 familles différentes, donc si nous mettons un symbole pour chaque famille. comme l'exemple suivant :-

| A | B | C | D | E |
|--------|--------|---------|-------|--------|
| ورود | فواكه | حمضيات | توابل | خشبيات |
| Floral | Fruity | Citrus | Spicy | Woody |
| Floral | Fruité | Agrumes | Épicé | Boisé |

سنختار مادة أولية من الأروما كيميكالز أو زيت أساسي أو أحادي يمثل كل عائلة.

We will choose a raw material from aroma chemicals, essential oil, or a single compound representing each family.

Nous choisirons une matière première parmi les produits chimiques aromatiques, les huiles essentielles ou un seul composé représentant chaque famille.

مثلاً من الورود ممكن تختار ريحان أو ورد أو ياسمين أو أسيتات بنزائل أو جيرانيوم .. ومن الحمضيات ممكن ليمون أو يوسفى أو برتقال أو سيترال أو لينالول، ومن الفواكه ممكن نختار فراولة أو تفاح أو توت أو جوز هند أو ايثيل مالتول أو الدهيدات، ومن التوابل ممكن حبهان (هيل) أو جوزة الطيب أو إيوجنول، ومن الخشبيات ممكن العود الطبيعي أو الكشميران أو صفرانول أو الباتشولى.

For example, from the floral family, you can choose basil, rose, jasmine, benzyl acetate, or geranium... From the citrus family, you can choose lemon, grapefruit, orange, citral, or linalool... From the fruity family, we can choose Strawberry, Apple, Berries, Coconut, Ethyl maltol, or Aldehydes... And from the Spices, we can choose Cardamom (heel), nutmeg, or eugenol... From the woody family, we can choose natural Oud, Cashmeran, Safranal, or Patchouli .

Par exemple, de la famille florale, vous pouvez choisir le basilic, la rose, le jasmin, l'acétate de benzyle ou le géranium... De la famille des agrumes, vous pouvez choisir le citron, le pamplemousse, l'orange, le citral ou le linalol.... De la famille des fruités, nous pouvons choisir la fraise, la pomme, les baies, la noix de coco, l'éthylmaltol ou les aldéhydes... Et parmi les épices, nous pouvons choisir la cardamome (talon), la noix de muscade ou l'eugénol.... De la famille boisée, nous pouvons choisir le Oud naturel, le Cashmeran, le Safranal ou le Patchouli.



المواد الأولية

وهي الزيوت الطبيعية أو الأساسية المستخرجة من النباتات حيث تأتي من الزهور أو قشور الثمار أو الساق، أو القلف، أو الجذور، وأيضاً العناصر المعزولة من الزيت الأساسي، مثل: السيترال، والليمونين، والجرانيوم، والإيوجنول.

Raw materials

These are natural or essential oils extracted from plants, originating from flowers, fruit peels, stems, bark, or roots. They also include components isolated from essential oils, such as citral, limonene, geraniol, and eugenol.

Les matières premières

Ce sont des huiles naturelles ou essentielles extraites des plantes, provenant des fleurs, des écorces de fruits, des tiges, de l'écorce ou des racines. Elles incluent également des composants isolés des huiles essentielles, tels que le citral, le limonène, le géraniol et l'eugénol.

يعنى ورد.

A



A means rose...

signifie rose...

يعنى فراولة من الفواكه

B



B means strawberry from the fruits.... signifie fraise parmi les fruits.

يعنى ليمون من الحمضيات

C



C means lemon from the citrus fruits... signifie citron des agrumes.

يعنى قرفة من التوابل

D



D means cinnamon from the spices... signifie cannelle parmi les épices.

العود مثلاً من الخشبيات

E



E means oud, for example, from the woods... signifie oud, par exemple, du bois

إن مجموعة الخشبيات سيمثلها العود بلا خلاف ولأن للعود جمهور خاص هو الخليجين بصفة خاصة .

سيكون للعود خلطات تتماشى مع قيمة العود، وسنعوض عائلة الخشبيات بالتوابل الحارة الخشبية

مثل القرفة أو القرنفل أو الجبهان أو جوزة الطيب .

The woody group will be represented by Oud without a doubt, and because Oud has a special audience, especially the Gulf people. Oud will have blends that match the value of Oud, We will compensate for the woody family with hot woody spices such as cinnamon or cloves or cardamom or nutmeg.

Le groupe boisé sera représenté par le Oud sans aucun doute, et parce que le Oud a un public particulier, notamment les habitants du Golfe. Le Oud aura des mélanges qui correspondent à la valeur du Oud.

Nous compenserons la famille boisée avec des épices boisées chaudes comme la cannelle, le clou de girofle, la cardamome ou la noix de muscade.

وأيضاً لأن العمل من خلال 5 عائلات قد يضاعف عدد الأكوردات، وذلك للتبسيط، في البداية سنكون في صدد 4 عائلات عطرية فقط، وسنقوم بوضع نسب مختلفة حيث الأعداد 1,2,3,4,5 تمثل عدد النقاط، فمثلاً A4 معناها 4 نقاط من الورد وهكذا أو بطريقة أخرى قد يكون العدد يمثل جرام أو أي وحدة قياس مناسبة للبيرفيومر (صانع العطر).

Also, because working through 5 families may double the number of accords, for simplification, in the beginning, we will only be dealing with 4 fragrance families.

We will put different ratios where the numbers 1, 2, 3, 4, 5 represent the number of points. For example, A4 means 4 points of rose and so on, or in another way, the number may represent grams or any unit of measurement suitable for the perfumer (perfume maker).

De plus, étant donné que le travail sur 5 familles peut doubler le nombre d'accords, pour simplifier, au début, nous ne traiterons que 4 familles de parfums.

Nous mettrons des ratios différents où les nombres 1, 2, 3, 4, 5 représentent le nombre de points. Par exemple, A4 signifie 4 points de rose et ainsi de suite, ou autrement, le nombre peut représenter des grammes ou toute unité de mesure appropriée pour le parfumeur (créateur de parfum).

فمثلاً:

*For example:

*Par exemple :

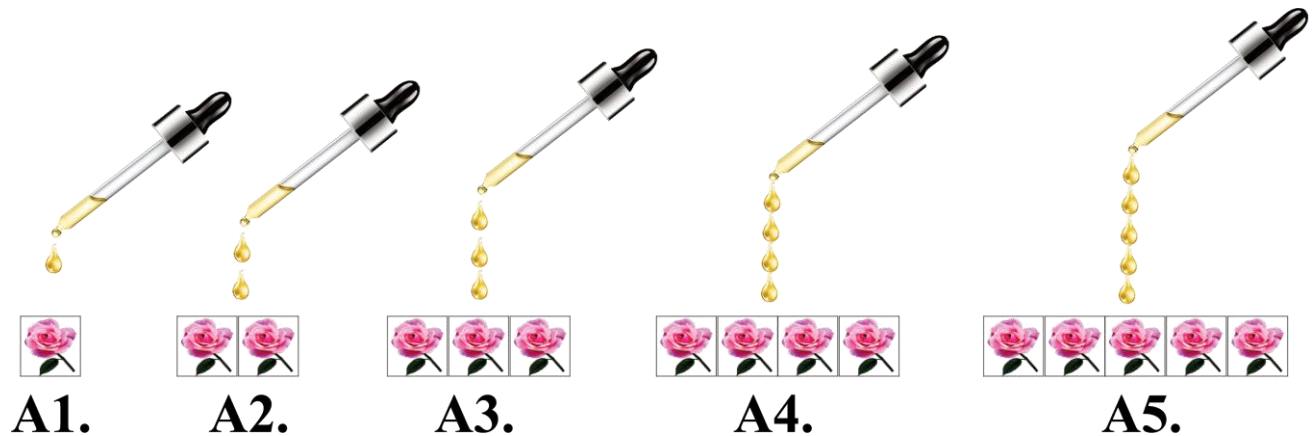

اختار المناسب لك ولكن الأسهل هو النقط والأفضل

Choose the one that suits you, but the easiest is the dots and the best

Choisissez celui qui vous convient, mais le plus simple est les points et le meilleur



A1.



A2.



A3.



A4.



A5.



B1.

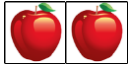

B2.

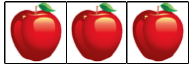

B3.

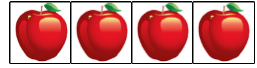

B4.



B5.



C1.

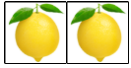

C2.

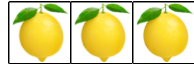

C3.

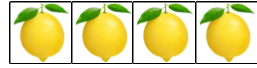

C4.

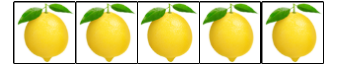

C5.



D1.



D2.



D3.



D4.



D5.

أولاً: أكورد من عائلة واحدة: يعني أكورد يتكون من التوابل فقط أو من الورود أو من الفواكه

مثل :- (ورد + ياسمين + ريحان + جيرانيوم + توليب).

مثلاً: *أكورد من الزهور

مثل :- (توت + تفاح + فراولة + إيثيل مالتول + الدهيد)

*أكورد من الفواكه

مثل :- (جوزة الطيب + قرنفل + حبهان (هيل) + فلفل اسود)

*أكورد من التوابل.

First: Accord from one family: It means an accord consisting of spices only, or of roses, or of fruits.

*For example"

* A floral accord: Like:- Rose + Jasmine + Basil + Geranium + Tulip.

*Fruit accord: Like:- (Berry +Apple +Strawberry +Ethyl Maltol +Aldehyde).

*Spice accord: Like:- (Nutmeg +Cloves +Cardamom +Black pepper).

Premièrement: Accord d'une seule famille: Cela signifie un accord composé uniquement d'épices, ou de roses, ou de fruits.

*Par exemple"

* un accord floral : Comme :- Rose + Jasmin + Basilic + Géranium + Tulipe.

*Accord de fruits : Comme :- (Baie +Pomme +Fraise +Éthyl maltol +Aldéhyde).

*Accord d'épices : Comme :- (Noix de muscade +Clous de girofle +Cardamome +Poivre noir).

قواعد بناء العطر:

Perfume Construction Rules:

Règles de construction des parfums :

أولاً: – التدرج فى نسب المكونات حتى لا يتكون عطر تصادمى.

-First - Gradation in the proportions of ingredients so that a clashing perfume is not created.

Premièrement - Gradation dans les proportions des ingrédients afin d'éviter la création d'un parfum discordant.

ثانياً: – الهوية: من الأفضل أن يكون العطر معلوم الهوية أى يغلب عليه اتجاه معين واضح ولو بنسبة قليلة.

-Second – Identity: _ It is better for the perfume to have a known identity, i.e., a certain clear direction prevails, even by a small percentage.

Deuxièmement – Identité: Il est préférable que le parfum ait une identité connue, c'est-à-dire qu'une certaine direction claire prédomine, même par un petit pourcentage.

ثالثاً: – القالب والزينة: لابد للعطر من قالب يحمل زينته والقالب لابد أن يزيد نسبته عن الثلثين أو 75% من الاكورد والزينة أو اللمسة تمثل النسبة المتبقية، ونضرب مثل التكوين العطرى الصحيح بالتورته.

قالب متمثل فى الكيكة يساوى تقريبا 75% والزينة تمثل 25% تقريبا، وكلما كان العطر واضح فى هويته كلما كان مناسباً وجذاباً للإنسان.

Third - The Mold and Decoration:

The perfume must have a mold that carries its decoration, and the mold must exceed two-thirds, or 75% of the accord, and the decoration or touch represents the remaining percentage.

We give the example of the correct perfume composition with a cake.

A mold represented by the cake equals approximately 75%, and the decoration represents approximately 25%.

The clearer the perfume is in its identity, the more suitable and attractive it is to humans.

Troisièmement - Le Moule et la Décoration:

Le parfum doit avoir un moule qui porte sa décoration, et le moule doit dépasser les deux tiers ou 75% de l'accord, et la décoration ou la touche représente le pourcentage restant.

Nous donnons l'exemple de la composition correcte d'un parfum avec un gâteau.

Un moule représenté par le gâteau équivaut à environ 75%, et la décoration représente environ 25%.

Plus le parfum est clair dans son identité, plus il est adapté et attrayant pour l'homme.

الأكوردات الناتجة من خلط العائلات العطرية الأربعة :-

** قاعدة الـ 60 أكورد

The accords resulting from mixing the four fragrance families:

** The 60 Accord Rule

Les accords résultant du mélange des quatre familles de parfums :

** La règle des 60 accords

*ملحوظات : وصف (فاكهي) = (حلو) = (شوجري)

*Notes: Description (Fruity) = (Sweet) = (Sugary)

*Remarques : Description (Fruité) = (Sucré) = (Sucré).

* المقصود بعطر وردى فاكهي :-

هو عطر أساسه أو الغالب عليه الورود بنسبة تزيد عن 75% وبه لمسات من الفاكهة تمثل 25%

تقريبا وهذا ماتم دراسته في قاعدة القالب والزينة وهوية العطر

The meaning of a rosy fruity perfume:

Is a perfume based on or dominated by roses by more than 75% and has touches of fruit representing approximately 25%, and this is what was studied in the base and ornament rule and the identity of the perfume.

La signification d'un parfum fruité rosé

Est un parfum à base de rose ou dominé par la rose à plus de 75 % et comportant des touches fruitées représentant environ 25 %, et c'est ce qui a été étudié dans la règle de la base et de l'ornement et l'identité du parfum.

* سنقوم باستخدام السلم العطري، وهي تدرج النسب باستخدام ورق الشم من العائلة الواحدة و لكن بنسب متدرجة

*We will use the perfume scale, which is the gradation of percentages, Using blotting paper from the same family but with graded percentages.

*We will use the perfume scale, which is the gradation of percentages, Using blotting paper from the same family but with graded percentages.

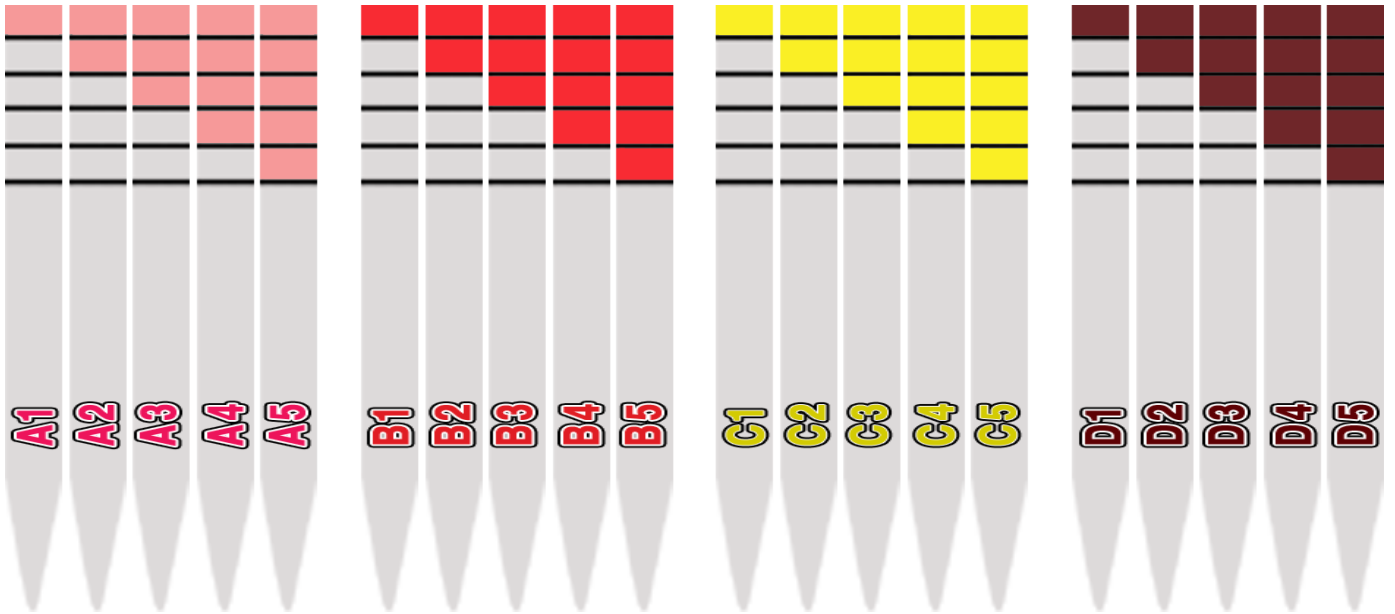

مثل الورد مثلاً:

like a rose for example

like a rose for example

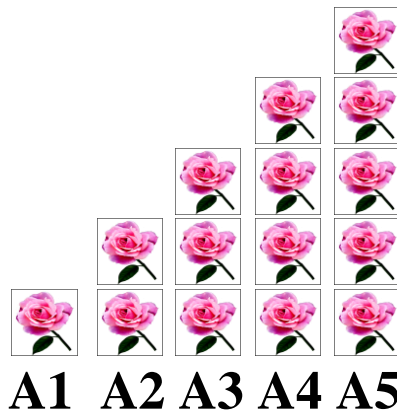

حيث أن الأرقام تفيد عدد النقط

Where the numbers indicate the number of points.

Là où les nombres indiquent le nombre de points.

وستكون نتيجة الاكوردات المحتملة بالتدرج العطري فى النسب عبارة عن ٦٠ أكورد وهي :-

And the result of the possible chords in the aromatic scale in the ratios will be 60 chords, which are:-

Et le résultat des accords possibles dans la gamme aromatique dans les ratios sera de 60 accords, qui sont :-

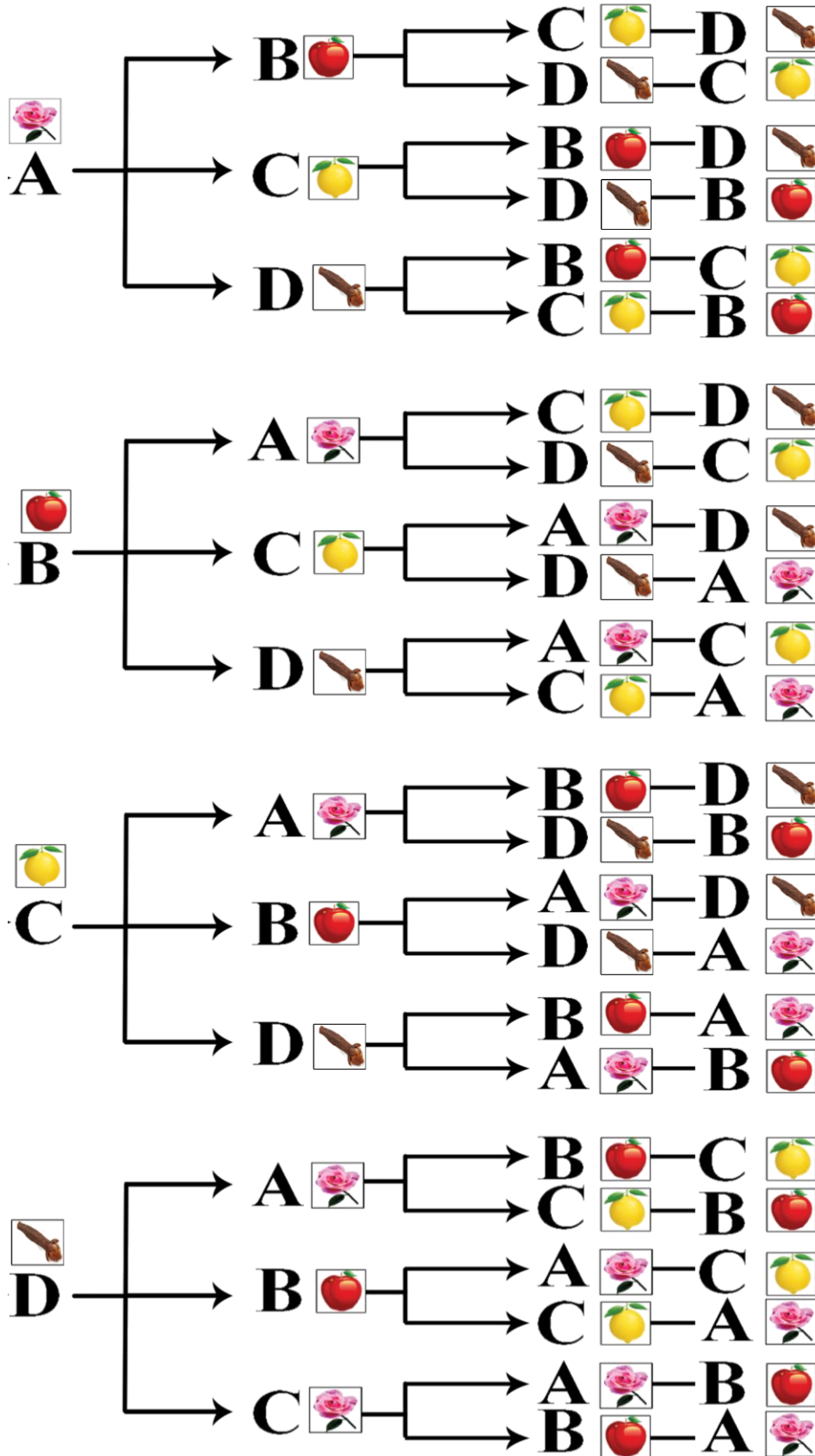

1- وردى فاكهى

1-Floral, Fruity

1- Floral, Fruité



A5 B1

2- وردى حمضى

2- Floral, Citrusy

2- Floral, Agrumesé

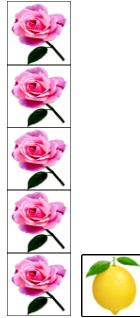

A5 C1

3- وردى تابلى

3- Floral, Spicy

3- Floral, Épicé

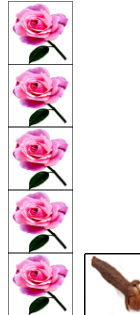

A5 D1

4- فاكهى وردى

4- Fruity, Floral

4- Fruité, Floral

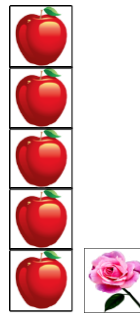

B5 A1

5- فاكهي حمضيات

5- Fruity, Citrus

5- Fruité, Agrumesé

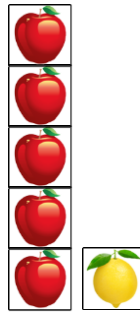

B5C1

6- فاكهي تابلي

6- Fruity, Spicy

6- Fruité, Épicé

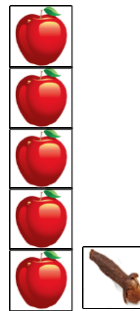

B5D1

7- حمضي وردي

7- Citrusy, Floral

7-Agrumesé, Floral

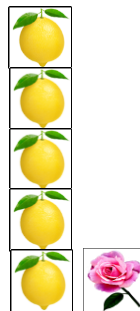

C5A1

8- حمضي فاكهي

8- Citrusy, Fruity

8- Agrumesé, Fruité

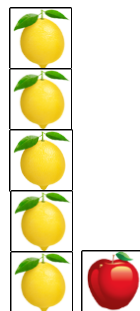

C5B1

9- حمضى تابلى

9- Citrusy, Spicy

9- Agrumesé, Épicé

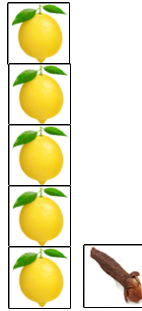

C5 D1

10- تابلى وردى

10- Spicy, Floral

10- Épicé, Floral

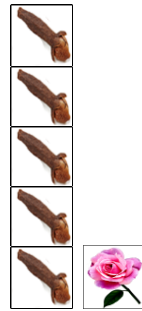

D5 A1

11- تابلى فاكهى

11- Spicy, Fruity

11- Épicé, fruité



D5 B1

12- تابلى حمضى

12- Spicy, Citrusy

12- Épicé, Agrumesés



D5 C1

و للأكوردات التي تتكون من ٣ عائلات:-

And for chords that consist of 3 families:-

Et pour les accords composés de 3 familles:-

13- Floral, Sugary, Citrusy

13- Floral, Sucré, Agrumesé

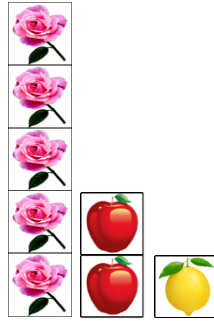

A5 B2 C1

13- وردى شوجرى حمضى

14- Floral, Sugary, Spicy

14- Floral, Sucré, Épicé

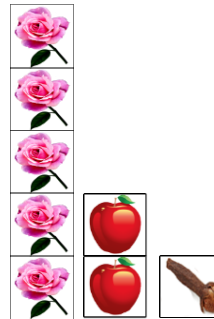

A5 B2 D1

14- وردى شوجرى تابلى

15- Floral, Citrusy, Sugary

15- Floral, Agrumesé, Sucré

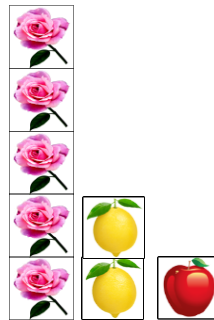

A5 C2 B1

15- وردى حمضى شوجرى

16- Floral, Citrusy, Spice

16- Floral, Agrumesé, Épicé

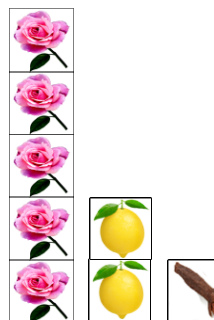

A5 C2 D1

16- وردى حمضى تابلى

17- وردى تابلى شوجرى

17- Floral, Spicy, Sugary

17- Floral, Épicé, Sucré

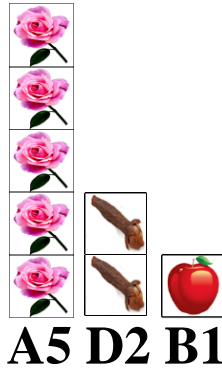

18- وردى تابلى حمضى

18- Floral, Spicy, Citrusy

18- Floral, Épicé, Agrumesé

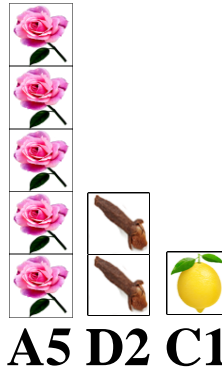

19- فاكهى وردى حمضى

19- Fruity, Floral, Citrusy

19- Fruité, Floral, Agrumesé

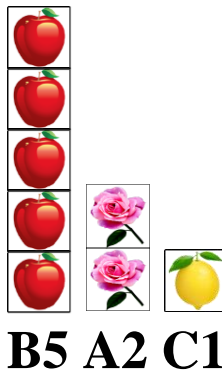

20- فاكهى وردى تابلى

20- Fruity, Floral, Spicy

20- Fruité, Floral, Épicé

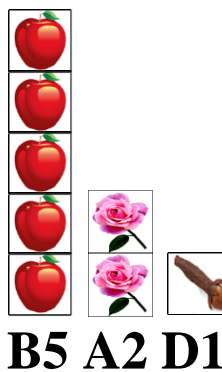

21- فاكهي حمضي وردى

21- Fruity, Citrusy, Floral
21- Fruité, Agrumesé, Floral

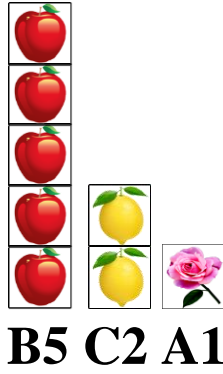

22- فاكهي حمضي تابلي

22- Fruity, Citrusy, Spicy
22- Fruité, Agrumesé, Épicé

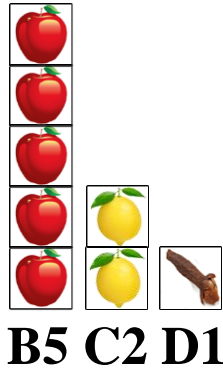

23- فاكهي تابلي وردى

23- Fruity, Spicy, Floral
23- Fruité, Épicé, Floral

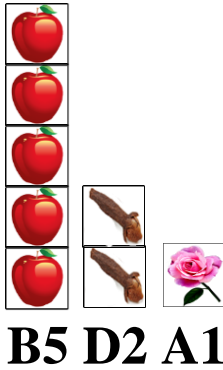

24- فاكهي تابلي حمضي

24- Fruity, Spicy, Citrusy
24- Fruité, Épicé, Agrumesé

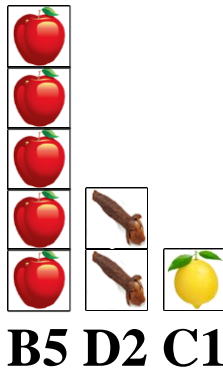

25- حمضى وردى فاكهى

25- Citrusy, Floral, Fruity

25- Agrumesé, Floral, Fruité

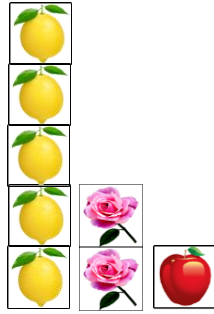

C5 A2 B1

26- حمضى وردى تابلى

26- Citrusy, Floral, Spicy

26- Agrumesé, Floral, Épicé

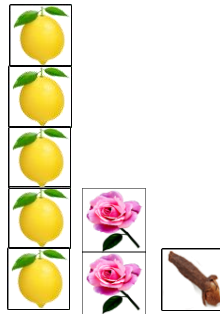

C5 A2 D1

27- حمضى فاكهى وردى

27- Citrusy, Fruity, Floral

27- Agrumesé, Fruité, Floral

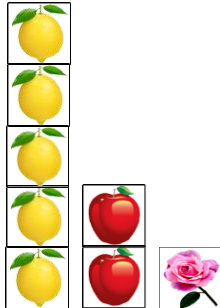

C5 B2 A1

28- حمضى فاكهى تابلى

28- Citrusy, Fruity, Spicy

28- Agrumesé, Fruité, Épicé

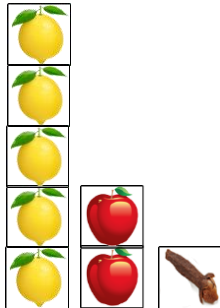

C5 B2 D1

29- حمضى تابلى وردى

29- Citrusy, Spicy, Floral

29- Agrumesé, Épicé, Floral

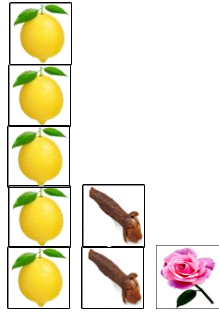

C5 D2 A1

30- حمضى تابلى فاكهى

30- Citrusy, Spicy, Fruity

30- Agrumesé, Épicé, Fruité

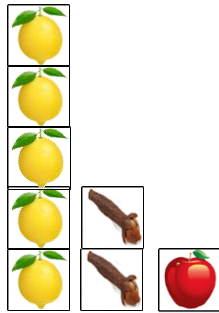

C5 D2 B1

31- تابلى وردى فاكهى

31- Spicy, Floral, Fruity

31- Épicé, Floral, Fruité

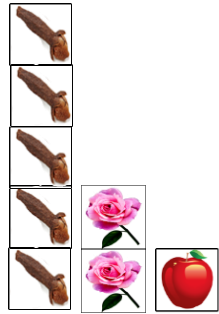

D5 A2 B1

32- تابلى وردى حمضى

32- Spicy, Floral, Citrusy

32- Épicé, Floral, Agrumesé

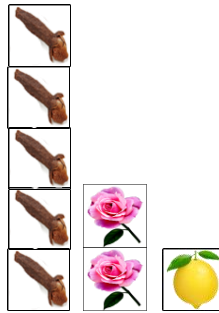

D5 A2 C1

33- تابلی فاکھی وردی

33- Spicy, Fruity, Floral

33- Épicé, Fruité, Floral

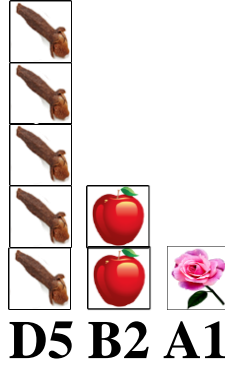

34- تابلی فاکھی حمضی

34- Spicy, Fruity, Citrusy

34- Épicé, Fruité, Agrumesé

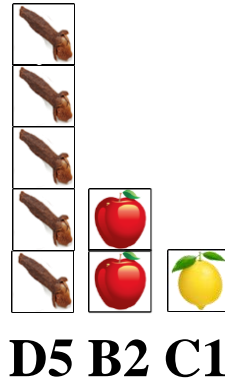

35- تابلی حمضی وردی

35- Spicy, Citrusy, Floral

35- Épicé, Agrumesé, Floral

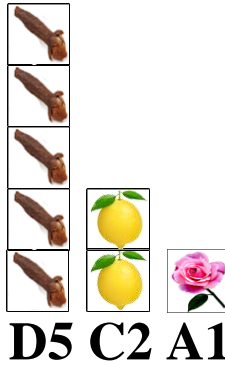

36- تابلی حمضی فاکھی

36- Spicy, Citrusy, Fruity

36- Épicé, Agrumesé, Fruité

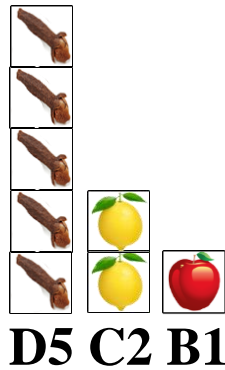

الأكوردات التي تتكون من 4 عائلات:-

The chords that consist of 4 families

Les accords composés de 4 familles

37- Floral, Sugary, Citrusy, Spicy

37- Floral, Sucré, Agrumesé, Épicé

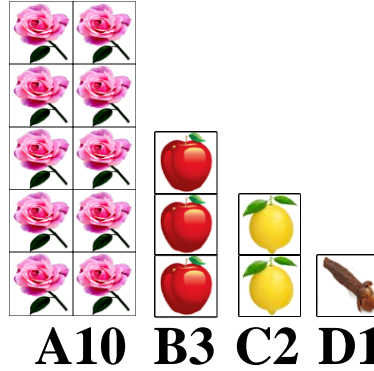

37- وردى شوجرى حمضى تابلى

38- Floral, Sugary, Spicy, Citrusy

38- Floral, Sucré, Épicé, Agrumesé

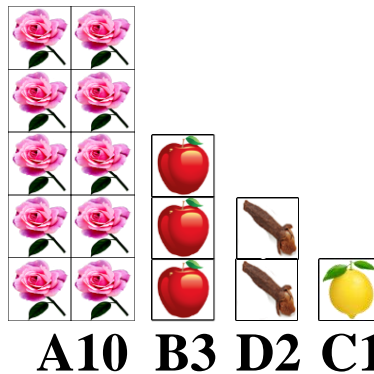

38- وردى شوجرى تابلى حمضى

39- Floral, Citrusy, Sugary, Spicy

39- Floral, Agrumesé, Sucré, Épicé

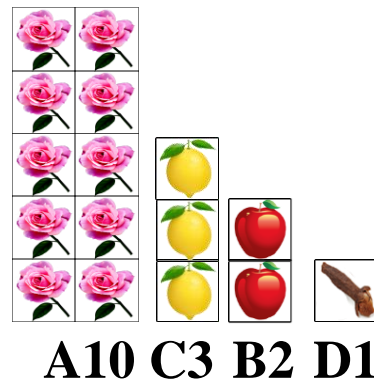

39- وردى حمضى شوجرى تابلى

40- Floral, Citrusy, Spicy, Sugary

40- Floral, Agrumesé, Épicé, Sucré

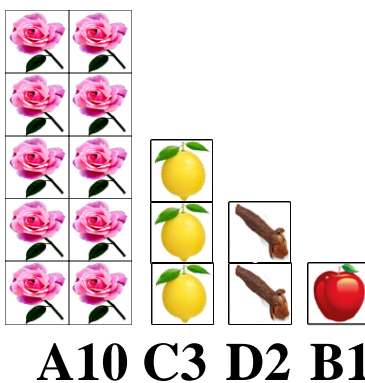

40- وردى حمضى تابلى شوجرى

41- وردى تابلی شوجری حمضي

41- Floral, Spicy, Sugary, Citrusy

41- Floral, Épicé, Sucré, Agrumesé

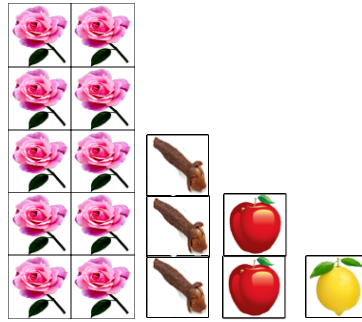

A10 D3 B2 C1

42- وردى تابلی حمضي فاكهي

42- Floral, Spicy, Citrusy, Fruity

42- Floral, Épicé, Agrumesé, Fruité

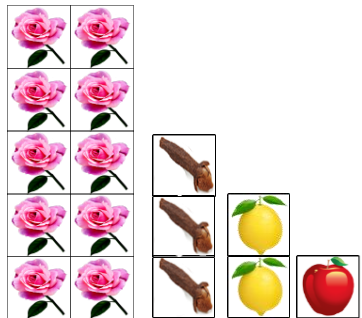

A10 D3 C2 B1

43- فاكهي وردى حمضي تابلی

43- Fruity, Floral, Citrusy, Spicy

43- Fruité, Floral, Agrumesé, Épicé

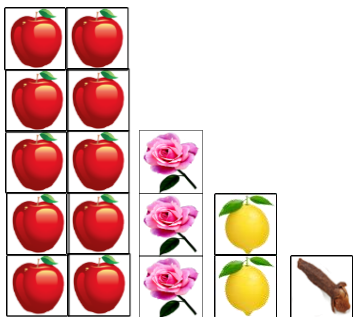

B10 A3 C2 D1

44- فاكهي وردى تابلی حمضي

44- Fruity, Floral, Spicy, Citrusy

44- Fruité, Floral, Épicé, Agrumesé

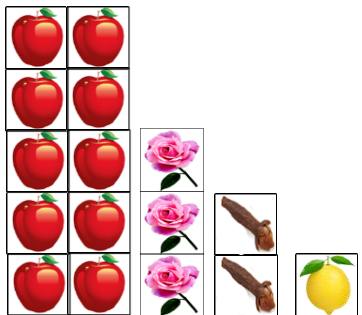

B10 A3 D2 C1

45- فاكهي حمضي وردى تابلي

45- Fruity, Citrusy, Floral, Spicy

45- Fruité, Agrumesé, Floral, Épicé

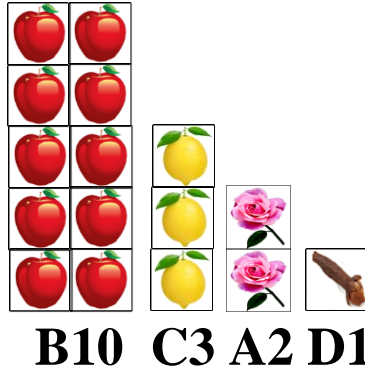

46- فاكهي حمضي تابلي وردى

46- Fruity, Citrusy, Spicy, Floral

46- Fruité, Agrumesé, Épicé, Floral

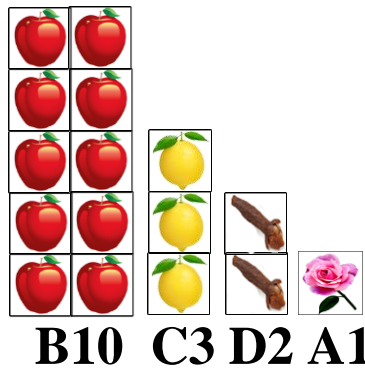

47- فاكهي تابلي وردى حمضي

47- Fruity, Spicy, Floral, Citrusy

47- Fruité, Épicé, Floral, Agrumesé

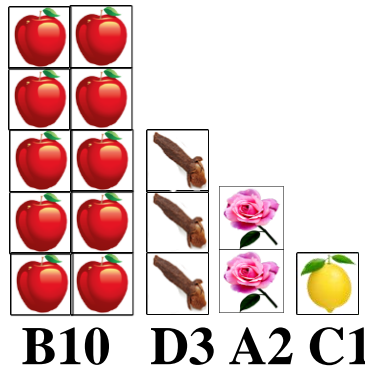

48- فاكهي تابلي حمضي وردى

48- Fruity, Spicy, Citrusy, Floral

48- Fruité, Épicé, Agrumesé, Floral

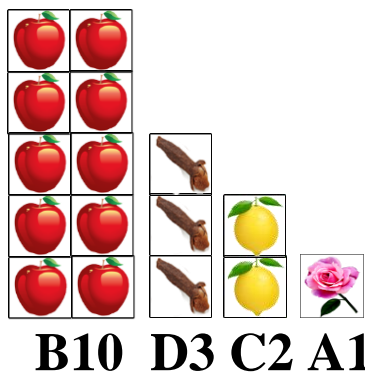

49- حمضى وردى فاكهى تابلى

49- Citrusy, Floral, Fruity, Spicy

49- Agrumesé, Floral, Fruité, Épicé

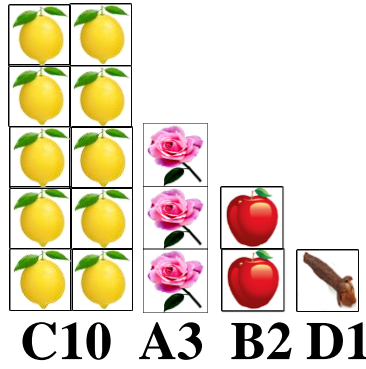

50- حمضى وردى فاكهى

50- Citrusy, Floral, Spicy, Fruity

50- Agrumesé, Floral, Épicé, Fruité

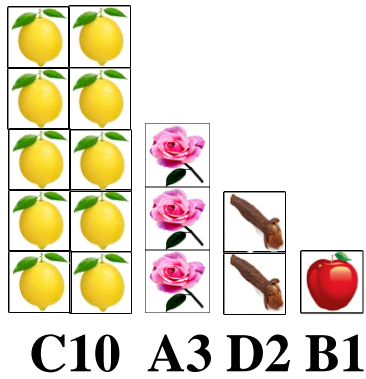

51- حمضى فاكهى وردى تابلى

51- Citrusy, Fruity, Floral, Spicy

51- Agrumesé, Fruité, Floral, Épicé

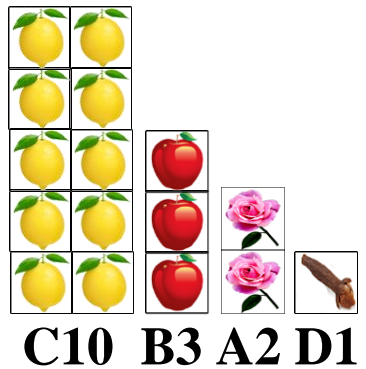

52- حمضى فاكهى تابلى وردى

52- Citrusy, Fruity, Spicy, Floral

52- Agrumesé, Fruité, Épicé, Floral

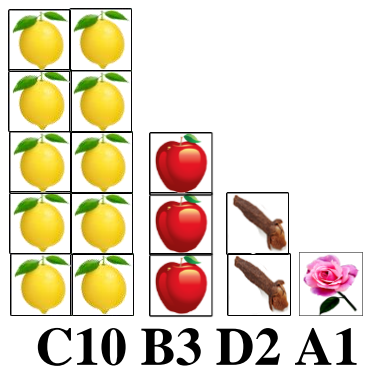

53- حمضى تابلى وردى فاكهى

53- Citrusy, Spicy, Floral, Fruity

53- Agrumesé, Épicé, Floral, Fruité

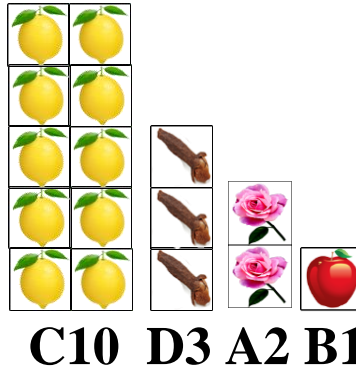

54- حمضى تابلى فاكهى وردى

54- Citrusy, Spicy, Fruity, Floral

54- Agrumesé, Épicé, Fruité, Floral

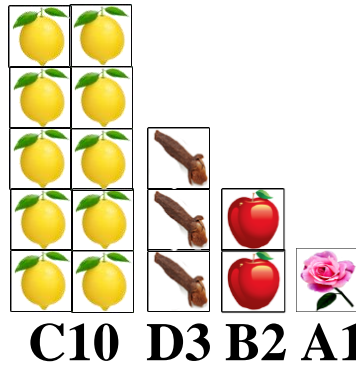

55- تابلى وردى فاكهى حمضى

55- Spicy, Floral, Fruity, Citrusy

55- Épicé, Floral, Fruité, Agrumesé

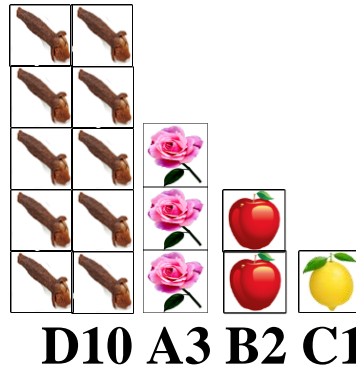

56- تابلى وردى حمضى فاكهى

56- Spicy, Floral, Citrusy, Fruity

56- Épicé, Floral, Agrumesé, Fruité

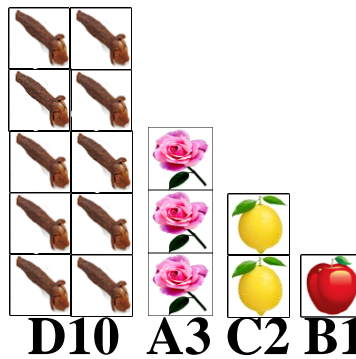

57- تابلی فاکھی وردی حمضی

57- Spicy, Fruity, Floral, Citrusy

57- Épicé, Fruité, Floral, Agrumesé

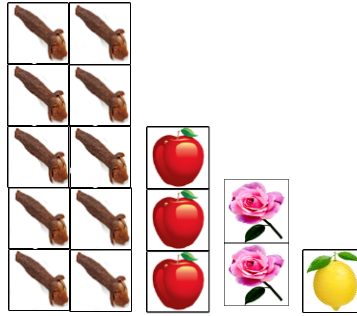

D10 B3 A2 C1

58- تابلی فاکھی حمضی وردی

58- Spicy, Fruity, Citrusy, Floral

58- Épicé, Fruité, Agrumesé, Floral

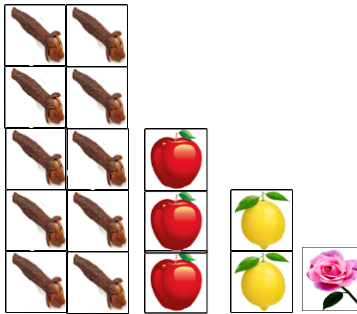

D10 B3 C2 A1

59- تابلی حمضی وردی فاکھی

59- Spicy, Citrusy, Floral, Fruity

59- Épicé, Agrumesé, Floral, Fruité

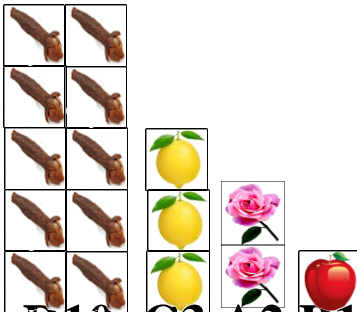

D10 C3 A2 B1

60- تابلی حمضی فاکھی وردی

60- Spicy, Citrusy, Fruity, Floral

60- Épicé, Agrumesé, Fruité, Floral

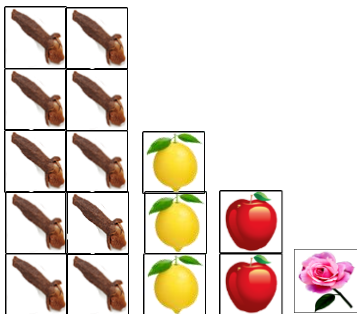

D10 C3 B2 A1

***** أكوردات العود المحتملة *****

Possible Oud Chords

Accords de oud possibles

The 64 Rule

Règle des 64

قاعدة الـ 64

سنتفق جميعاً ان العود يستخدم دائماً كقالب ولا يصلح للزينة.

للاحتفاظ باتجاه العود كعطر، و باستخدام النتائج السابقة يمكن ان نستعملها كلها كزينة لقالب العود

فقط سنقوم بإضافة العود بنسبة 60% : 70% على الـ 60 أكورد السابقين لنحصل بذلك على جميع الاحتمالات الواردة لخطات الورد بطريقة علمية حديثة.

We all agree that oud is always used as a mold and is not suitable for decoration.

To preserve the direction of oud as a fragrance

And using the previous results, we can use them all as a decoration for the oud mold.

Only we will add oud at a ratio of 60%: 70% On the 60 previous chords, we will thus obtain all the possible combinations of roses in a modern scientific way

Nous sommes tous d'accord que le oud est toujours utilisé comme moule et ne convient pas à la décoration.

Pour conserver la direction du oud comme parfum

Et en utilisant les résultats précédents, nous pouvons tous les utiliser comme décoration pour le moule à oud

Seulement, nous allons ajouter le oud à un ratio de 60% : 70% Sur les 60 accords précédents pour obtenir ainsi toutes les possibilités de mélanges de roses d'une manière scientifique moderne.

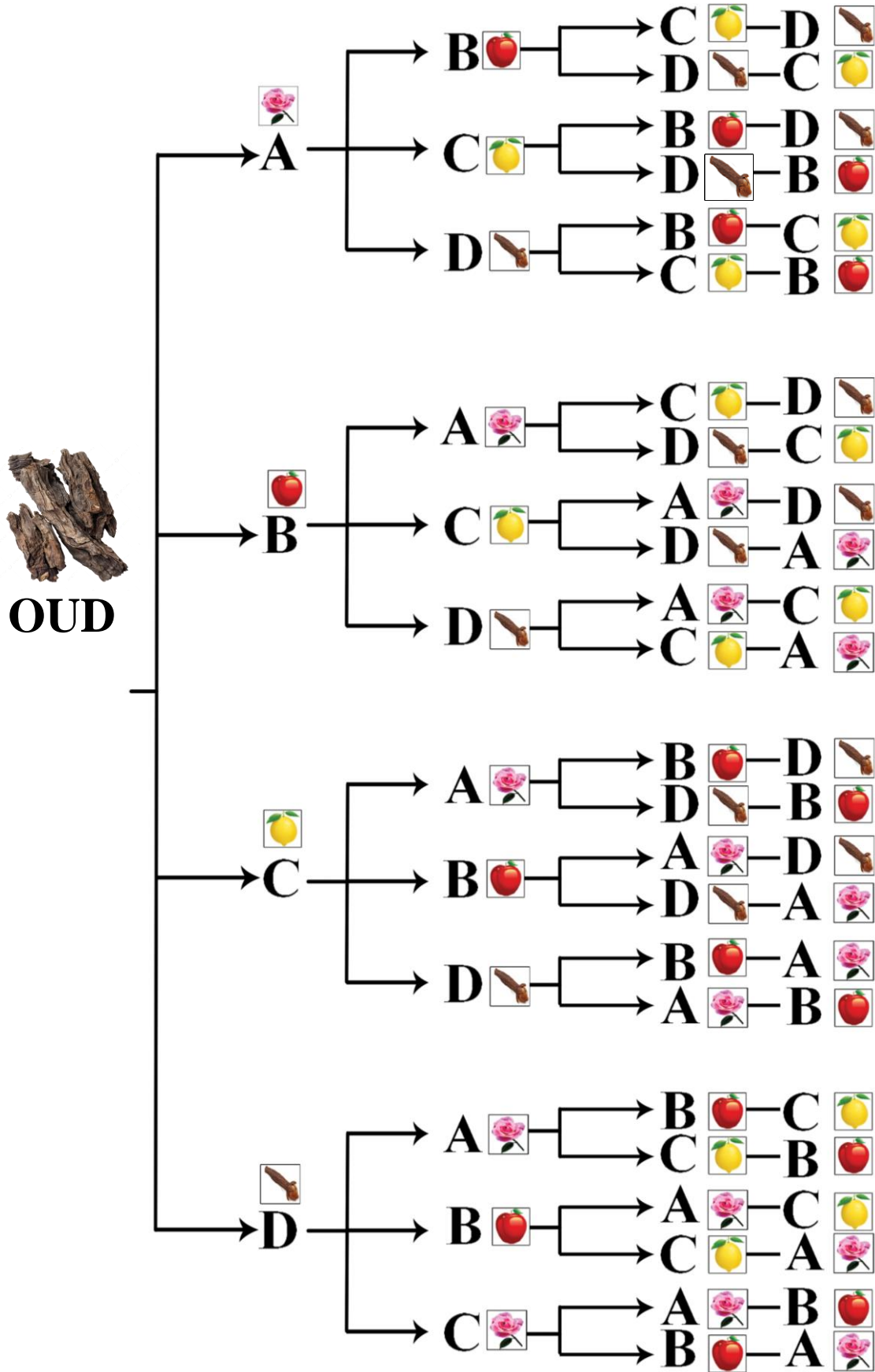

1- عود وردى

s1- Oud, Floral

1- Oud, Floral



E10 A1

2- عود فاكهى

2- Oud, Fruity

2- Oud, Fruité

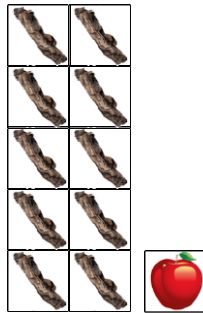

E10 B1

3- عود حمضى

3- Oud, Citrusy

3- Oud, Agrumesé



E10 C1

4- عود تابلى

4- Oud, Spicy

4- Oud, Épicé

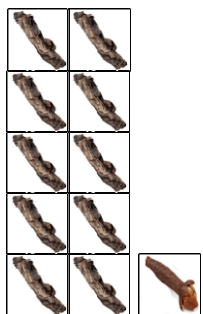

E10 D1

أكورد يتكون من 3 عائلات عطرية

5- Oud, Floral, Fruity

5- Oud, Floral, Fruité

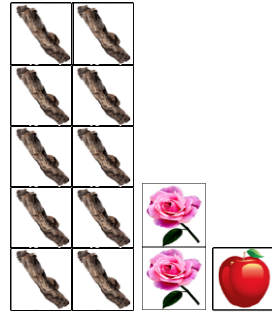

E10 A2 B1

5- عود وردى فاكهي

6-Oud, Floral, Citrusy

6- Oud, Floral, Agrumesé

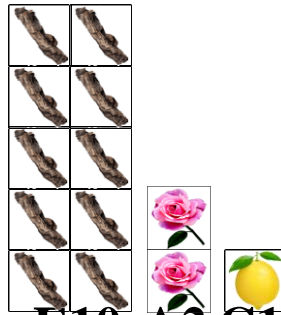

E10 A2 C1

6- عود وردى حمضى

7- Oud, Floral, Spicy

7- Oud, Floral, Épicé



E10 A2 D1

7- عود وردى تابلى

8- Oud, Fruity, Floral

8- Oud, Fruité, Floral

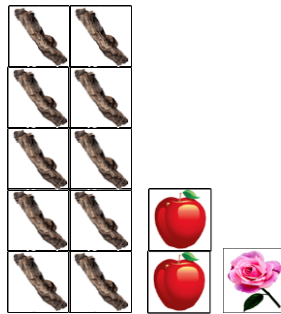

E10 B2 A1

8- عود فاكهي وردى

9- عود فاكهي حمضيات

9- Oud, Fruity, Citrus

9- Oud, Fruité, Agrumesé

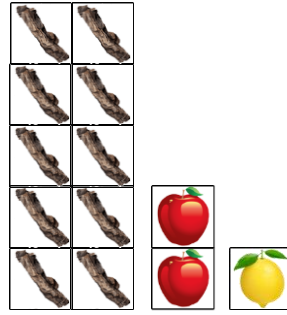

E10 B2 C1

10- عود فاكهي تابلي

10- Oud, Fruity, Spicy

10- Oud, Fruité, Épicé

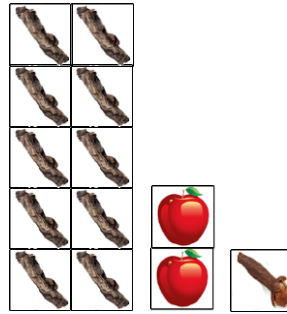

E10 B2 D1

11- عود حمضي وردى

11- Oud, Citrusy, Rose

11- Oud, Agrumes Et À La Rose

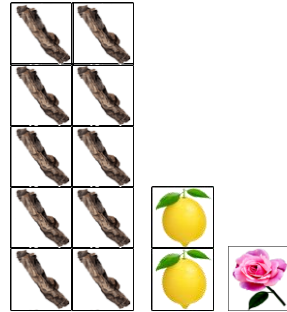

E10 C2 A1

12- عود حمضي فاكهي

12- Oud, Citrusy, Fruity

12- Oud, Agrumesé ,Fruité

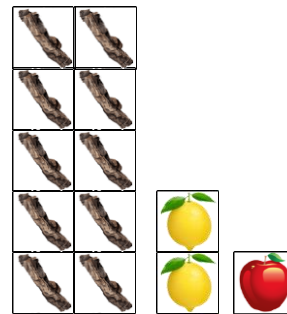

E10 C2 B1

13- عود حمضى تابلى

13- Oud, Citrusy Spicy

13- Oud, Agrumesé, Épicé

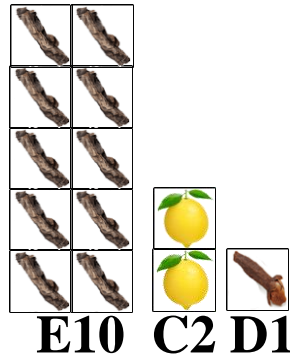

14- عود تابلى وردى

14- Oud, Spicy, Floral

14- Oud, Épicé, Floral

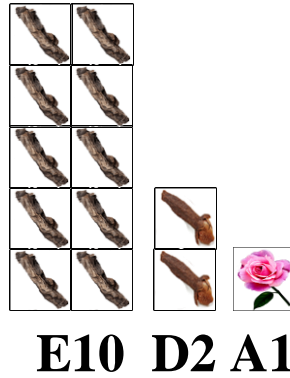

15- عود تابلى فاكهى

15- Oud, Spicy, Fruity

15- Oud, Épicé Fruité

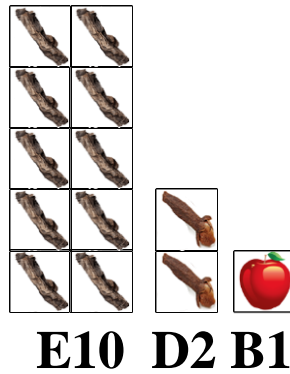

16- عود تابلى حمضى

16- Oud, Spicy, Citrusy

16- Oud, Épicé Agrumesé



وللاكوردات التي تتكون من 4 عائلات :-

And for chords that consist of 4 families:-

Et pour les accords composés de 4 familles:-

17- Oud, Floral, Sugary, Citrusy

17- Oud, Floral, Sucré, Agrumesé

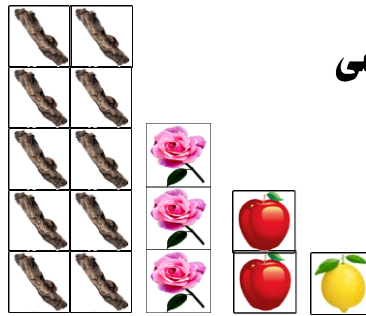

E10 A3 B2 C1

17- عود وردى شوجرى حمضى

18- Oud, floral, sugary, spicy

18- Oud, floral, Sucré, Épicé

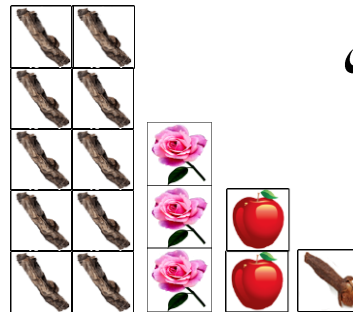

E10 A3 B2 D1

18- عود وردى شوجرى تابلى

19- Oud, Floral, Citrusy, Sugary

19- Oud, Floral, Agrumesé, Sucré

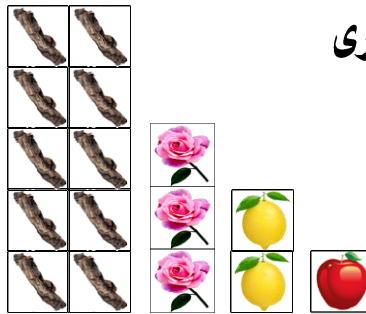

E10 A3 C2 B1

19- عود وردى حمضى شوجرى

20- Oud, Floral, Citrusy, Spicy

20- Oud, Floral, Agrumesé, Épicé

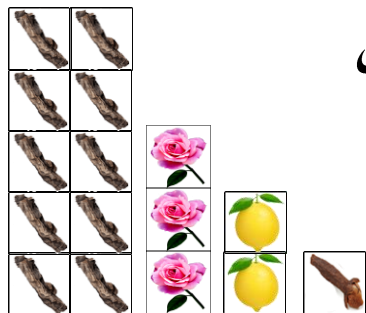

E10 A3 C2 D1

20- عود وردى حمضى تابلى

21- عود وردى تابلى شوجرى

21- Oud, Floral, Spicy, Sugary

21- Oud, Floral, Épicé, Sucré

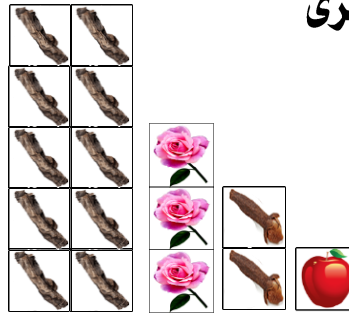

E10 A3 D2 B1

22- عود وردى تابلى حمضى

22- Oud, Floral, Spicy, Citrusy

22- Oud, Floral, Épicé, Agrumesé

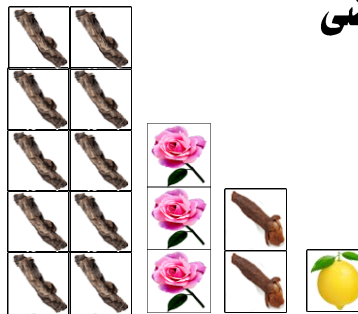

E10 A3 D2 C1

23- عود فاكهى وردى حمضى

23- Oud, Fruity, Floral, Citrusy

23- Oud, Fruité, Floral, Agrumesé

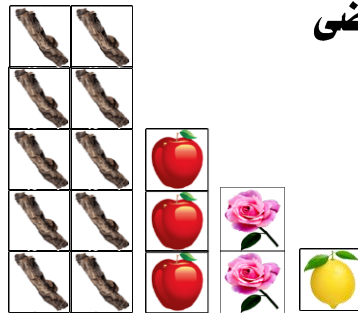

E10 B3 A2 C1

24- عود فاكهى وردى تابلى

24- Oud, Fruity, Floral, Spicy

24- Oud, Fruité, Floral, Épicé

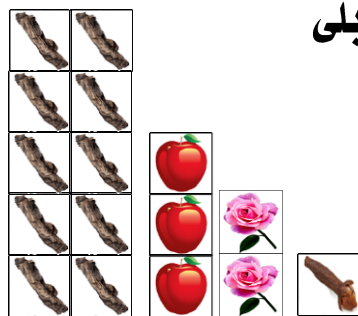

E10 B3 A2 D1

25- عود فاكهي حمضي وردى

25- Oud, Fruity, Citrusy, Floral
25- Oud, Fruité, Agrumesé, Floral

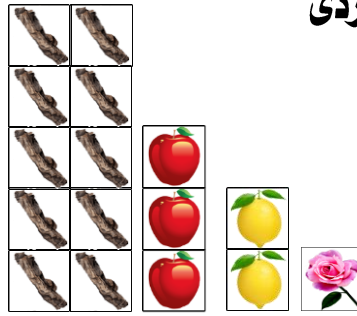

E10 B3 C2 A1

26- عود فاكهي حمضي تابلي

26- Oud, Fruity, Citrusy, Spice
26- Oud, Fruité, Agrumesé, Épicé

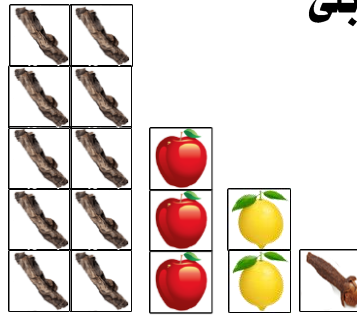

E10 B3 C2 D1

27- عود فاكهي تابلي وردى

27- Oud, Fruity, Spice, Floral
27- Oud, Fruité, Épicé, Floral

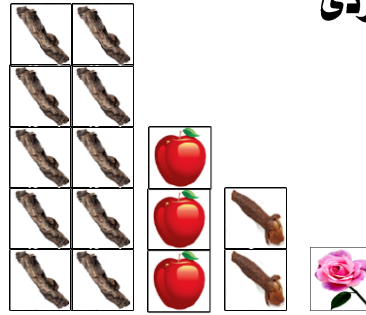

E10 B3 D2 A1

28- عود فاكهي تابلي حمضي

28- Oud, Fruity, Spicy, Citrusy
28- Oud, Fruité, Épicé, Agrumesé

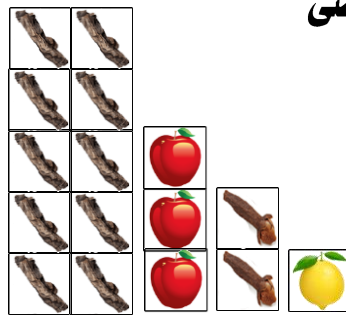

E10 B3 D2 C1

29- عود حمضى وردى فاكهى

29- Oud, Citrusy, Floral, Fruity

29- Oud, Agrumesé, Floral, Fruité

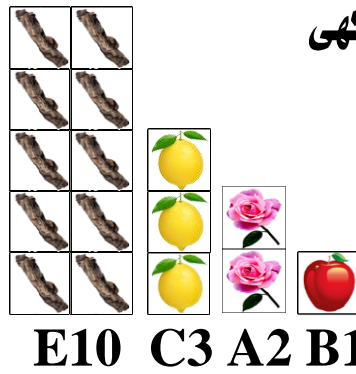

30- عود حمضى وردى تابلى

30- Oud, Citrusy, Floral, Spicy

30- Oud, Agrumesé, Floral, Épicé

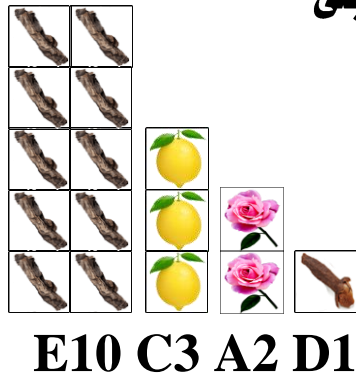

31 - عود حمضى فاكهى وردى

31- Oud, Citrusy, Fruity, Floral

31- Oud, Agrumesé, Fruité, Floral

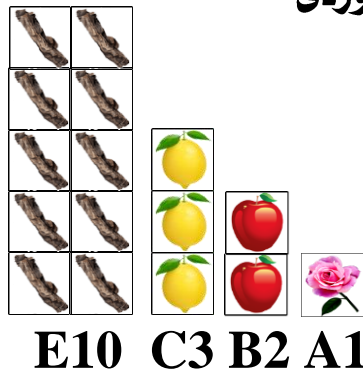

32- عود حمضى فاكهى تابلى

32- Oud, Citrusy Fruity, Spicy

32- Oud, Agrumesé, Fruité, Épicé

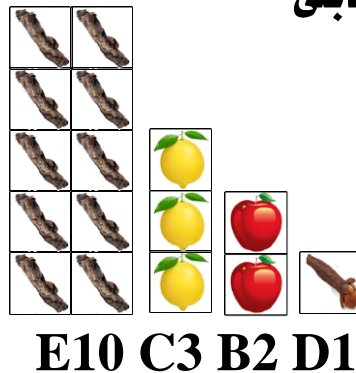

33- عود حمضى تابلى وردى

33- Oud, Citrusy, Spicy, Floral

33- Oud, Agrumesé, Épicé, Floral

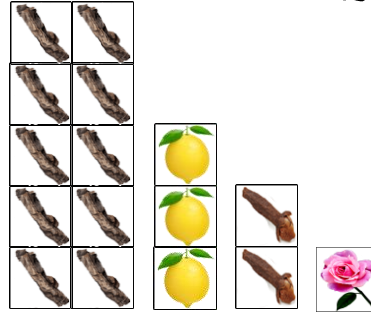

E10 C3 D2 A1

34- عود حمضى تابلى فاكهى

34- Oud, Citrusy, Spicy, Fruity

34- Oud, Agrumesé, Épicé, Fruité

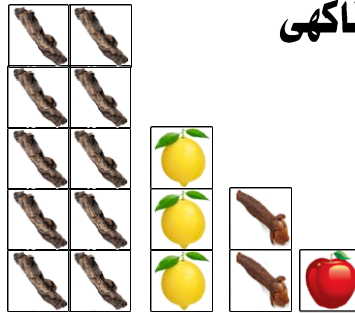

E10 C3 D2 B1

35- عود تابلى وردى فاكهى

35- Oud, Spice, Floral, Fruity

35- Oud, Épicé, Floral, Fruité

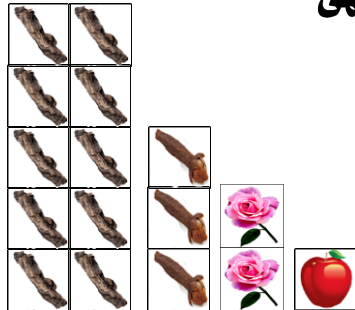

E10 D3 A2 B1

36- عود تابلى وردى حمضى

35- Oud, Spice, Floral, Citrusy

35- Oud, Épicé, Floral, Agrumesé

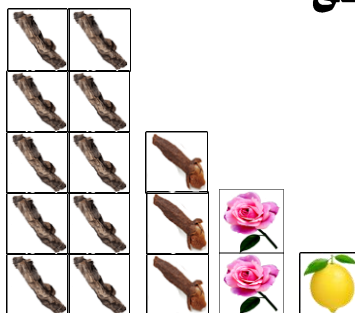

E10 D3 A2 C1

37- عود تابلی فاکھی وردی

37- Oud, Spicy, Fruity, Floral

37- Oud, Épicé, Fruité, Floral

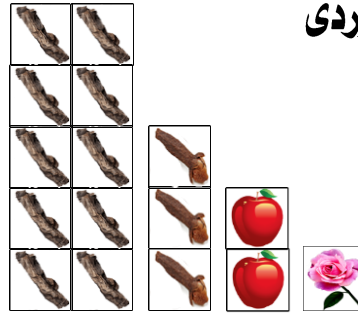

E10 D3 B2 A1

38- عود تابلی فاکھی حمضی

38- Oud, Spicy, Fruity, Citrusy

38- Oud, Épicée, Fruité, Agrumesé

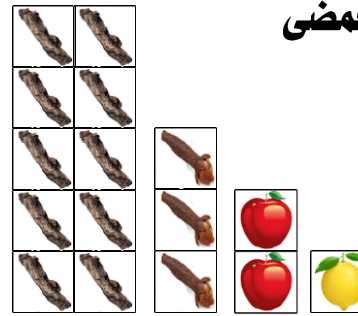

E10 D3 B2 C1

39- عود تابلی حمضی وردی

39- Oud, Spicy, Citrusy, Floral

39- Oud, Épicé, Agrumesé, Floral

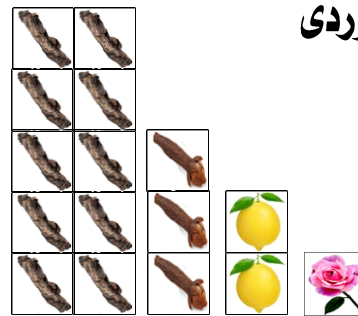

E10 D3 C2 A1

40- عود تابلی حمضی فاکھی

40- Oud, Spicy, Citrusy, Fruity

40- Oud, Épicé, Agrumesé, Fruité

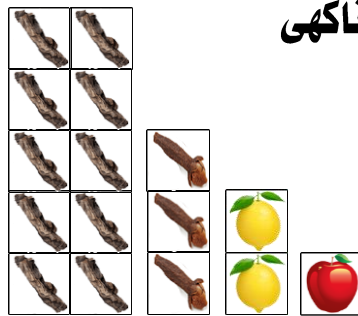

E10 D3 C2 B1

الأكوردات التي تتكون من 5 عائلات:-

The chords that consist of 5 families

Les accords composés de 5 familles

41- Oud, Floral, Sugary, Citrusy, Spicy

41- Oud, Floral, Sucré, Agrumesé, Épicé

41- عود وردى شوجرى حمضى تابلى

E15 A4 B3 C2 D1

42- Oud, Floral, Sugary, Spicy, Sour

42- Oud, Floral, Sucré, Épicé, Agrumesé

42- عود وردى شوجرى تابلى حمضى

E15 A4 B3 D2 C1

43- Oud, Floral, Citrusy, Sugary, Spicy

43- Oud, Floral, Agrumesé, Sucré, Épicé

43- عود وردى حمضى شوجرى تابلى

E15 A4 C3 B2 D1

44- Oud, Floral, Citrusy, Spicy, Sugary

44- Oud, Floral, Agrumesé, Épicé, Sucré

44- عود وردى حمضى تابلى شوجرى

E15 A4 C3 D2 B1

45- عود وردى تابلى شوجرى حمضى

45- Oud, Floral, Spicy, Sugary, Citrusy

45- Oud, Floral, Épicé, Sucré, Agrumesé

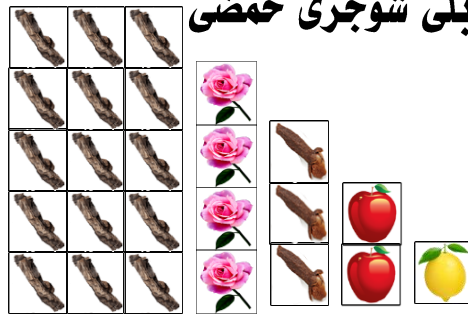

E15 A4 D3 B2 C1

46- عود وردى تابلى حمضى فاكهى

46- Oud, Floral, Spicy, Citrusy, Fruity

46- Oud, Floral, Épicé, Agrumesé, Fruité

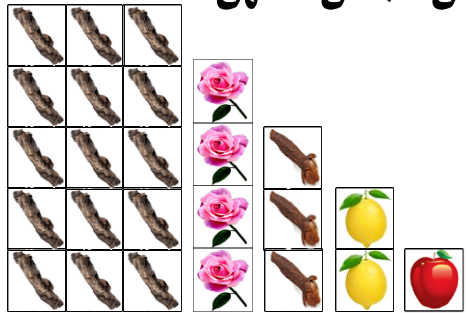

E15 A4 D3 C2 B1

47- عود فاكهى وردى حمضى تابلى

47- Oud, Fruity, Floral, Citrusy, Spicy

47- Oud, Fruité, Floral, Agrumesé, Épicé

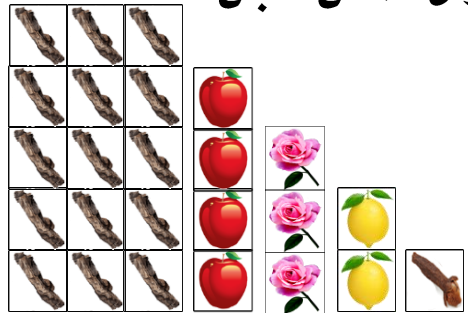

E15 B4 A3 C2 D1

48- عود فاكهى وردى تابلى حمضى

48- Oud, Fruity, Floral, Spicy, Citrusy

48- Oud, Fruité, Floral, Épicé, Agrumesé

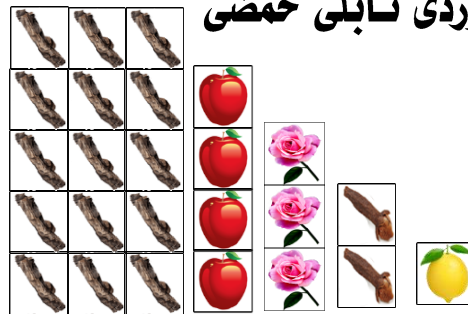

E15 B4 A3 D2 C1

49- عود فاكهى حمضى وردى تابلى

49- Oud, Fruity, Citrusy, Floral, Spicy

49- Oud, Fruité, Agrumesé, Floral, Épicé

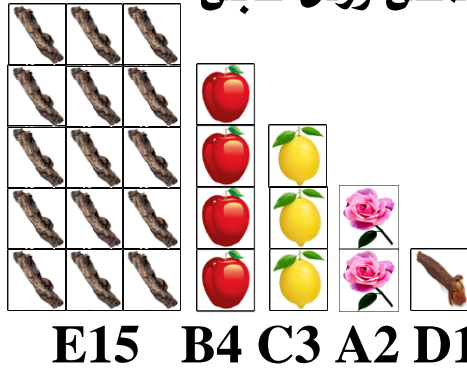

50- عود فاكهى حمضى تابلى وردى

50- Oud, Fruity, Citrusy, Spicy, Floral

50- Oud, Fruité, Agrumesé, Épicé, Floral



51- عود فاكهى تابلى وردى حمضى

51- Oud, Fruity, Spicy, Floral, Citrusy

51- Oud, Fruité, Épicé, Floral, Agrumesé

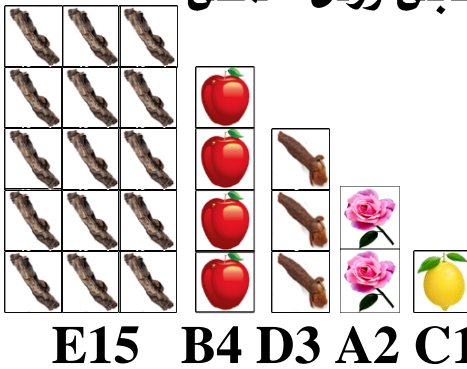

52- عود فاكهى تابلى حمضى وردى

52- Oud, Fruity, Spicy, Citrusy, Floral

52- Oud, Fruité, Épicé, Agrumesé, Floral

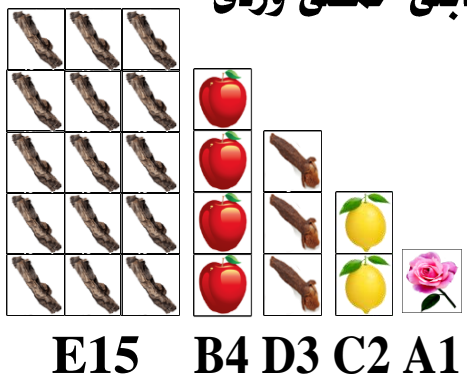

53- عود حمضى وردى فاكهى تابلى

53- Oud, Citrusy, Floral, Fruity, Spicy

53- Oud, Agrumesé, Floral, Fruité, Épicé

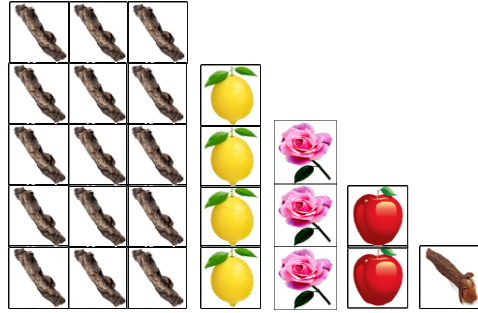

E15 C4 A3 B2 D1

54- عود حمضى وردى تابلى فاكهى

54- Oud, Citrusy, Floral, Spicy, Fruity

54- Oud, Agrumesé, Floral, Épicé, Fruité

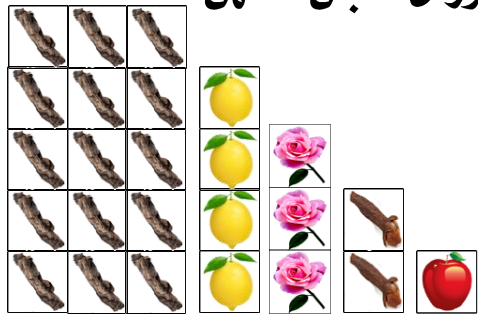

E15 C4 A3 D2 B1

55- عود حمضى فاكهى وردى تابلى

55- Oud, Citrusy, Fruity, Floral, Spicy

55- Oud, Agrumesé, Fruité, Floral, Épicé

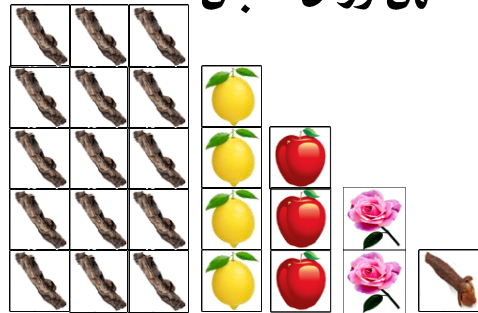

E15 C4 B3 A2 D1

56- عود حمضى فاكهى تابلى وردى

56- Oud, Citrusy, Fruity, Spicy, Floral

56- Oud, Agrumesé, Fruité, Épicé, Floral

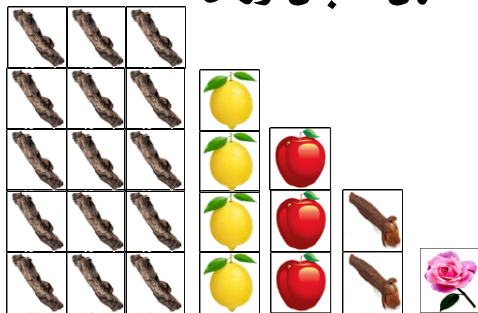

E15 C4 B3 D2 A1

57- عود حمضى تابلى وردى فاكهى

57- Oud, Citrusy, Spicy, Floral, Fruity

57- Oud, Agrumesé, Épicé, Floral, Fruité

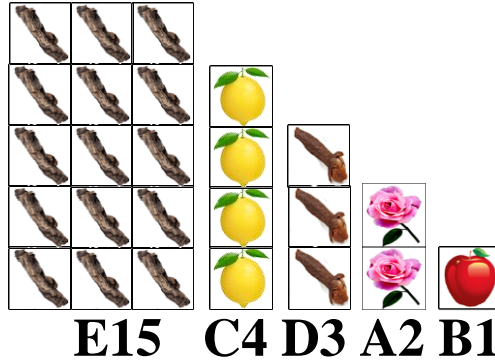

58- عود حمضى تابلى فاكهى وردى

58- Oud, Citrusy, Spicy, Fruity, Floral

58- Oud, Agrumesé, Épicé, Fruité , Floral

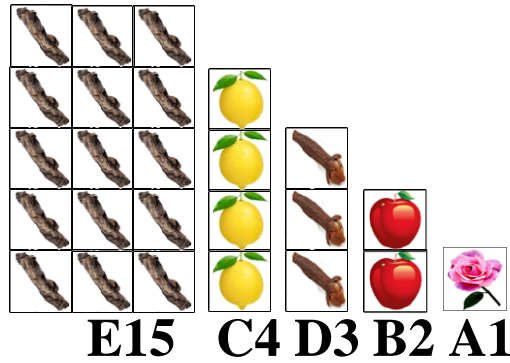

59- عود تابلى وردى فاكهى حمضى

59- Oud, Spicy, Floral, Fruity, Citrusy

59- Oud, Épicé, Floral, Fruité, Agrumesé

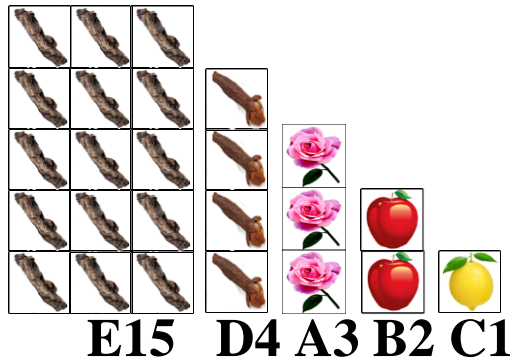

60- عود تابلى وردى حمضى فاكهى

60- Oud, Spicy, Floral, Citrusy, Fruity

60- Oud, Épicé, Floral, Agrumes, Fruité

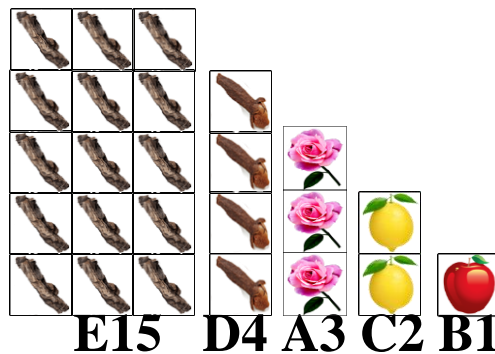

61- عود تابلی فاکھی وردی حمضی

61- Oud, Spicy, Fruity, Floral, Citrusy

61- Oud, Épicé, Fruité, Floral, Agrumesé

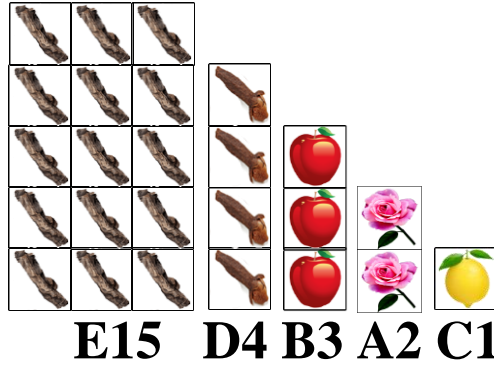

62- عود تابلی فاکھی حمضی وردی

62- Oud, Spicy, Fruity, Citrusy, Floral

62- Oud, Épicé, Fruité, Agrumesé, Floral

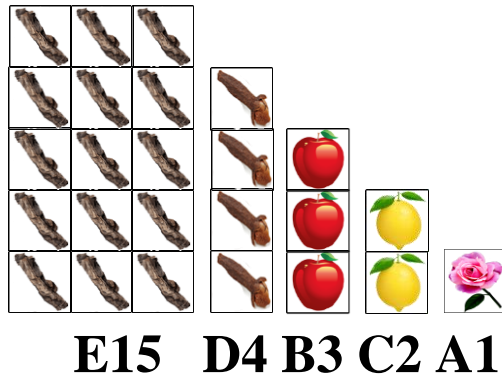

63- عود تابلی حمضی وردی فاکھی

63- Oud, Spicy, Citrusy, Floral, Fruity

63- Oud, Épicé, Agrumesé, Floral, Fruité

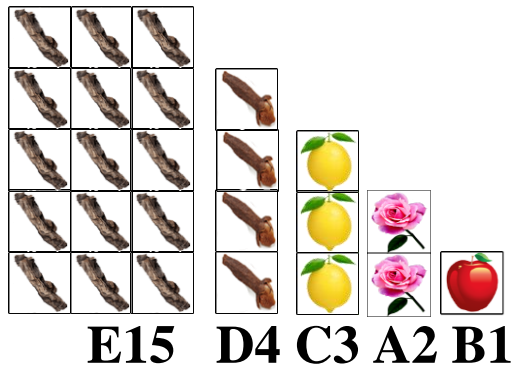

64- عود تابلی حمضی فاکھی وردی

64- Oud, Spicy, Citrusy, Floral, Fruity

64- Oud, Épicé, Agrumesé, Fruité, Floral

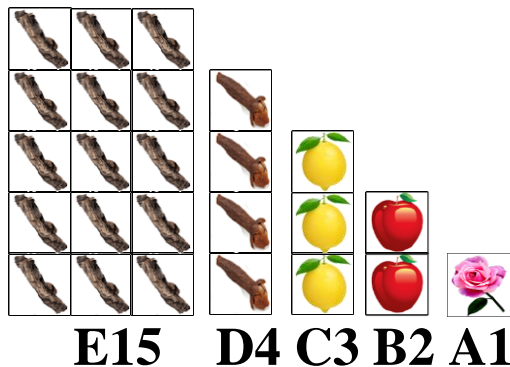

خريطة تصميم العطور

PERFUME DESIGN MAP
CARTE DE CONCEPTION DE PARFUMS

تجربة الحصول على حوالي 1187 أكورد باستخدام ورق الشم

أولاً: تكوين 4 مجموعات من ورق الشم، كل مجموعة تحتوي على 5 ورقات، بنسب مختلفة من العائلات الأربعة.

The experience of getting about 1187 chords using litmus paper. First, forming 4 groups of litmus paper, each group containing 5 papers, With different proportions of the four families.

Expérience d'obtention d'environ 1187 accords en utilisant du papier tournesol. Premièrement, former 4 groupes de papier tournesol, chaque groupe contenant 5 feuilles. avec des proportions différentes des quatre familles.

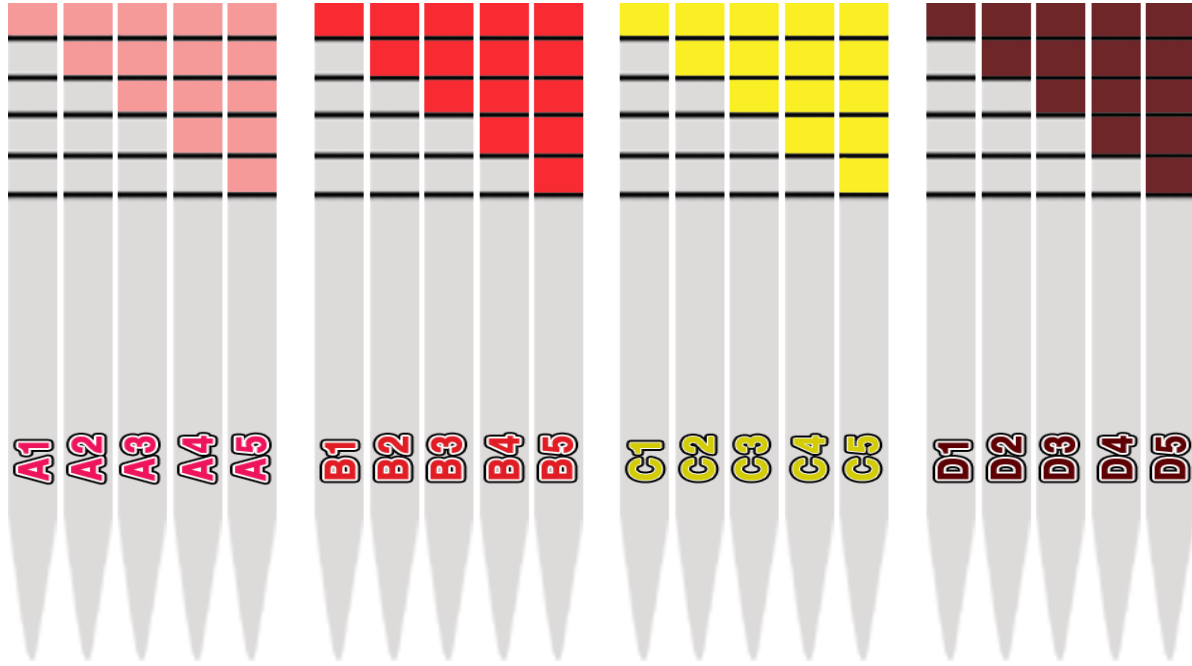

النتيجة

150 أكورد بهم (30 مكرر) من خلط عائلتين

500 أكورد بهم (40 مكرر) من خلط 3 عائلات

625 أكورد بهم (18 مكرر) من خلط 4 عائلات

****ملحوظة:** إن العلامة الموجودة تحت أي حرف على سبيل المثال A تدل على أنه مكرر يمكن حذفه،

أو تجاهله.

The result

150chords with (30 repeated) from mixing 2 families.
3 families.500chords with (40 repeated) from mixing
625chords with (18 repeated) from mixing 4 families****Note:** The mark below any letter, for example A, indicates that it is repeated and can be deleted or ignored.

le résultat

150accords avec (30 répétés) de mélange de 2 familles.
de 3 familles.500accords avec (40 répétés) de mélange
625accords avec (18 répétés) de mélange de 4 familles****Remarque :** Le signe sous une lettre, par exemple A, indique qu'elle est répétée et peut être supprimée ou ignorée.

Accord A, B

*أكورد A ,B



A1



(B1. B2. B3. B4. B5.)



A2



(B1. B2. B3. B4. B5.)



A3

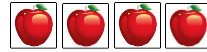
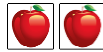

(B1. B2. B3. B4. B5.)



A4



(B1. B2. B3. B4. B5.)



A5

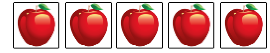

(B1. B2. B3. B4. B5.)

Accord A,C

*أكورد A,C



A1



(C1. C2. C3. C4. C5)



A2



(C1. C2. C3. C4. C5)



A3



(C1. C2. C3. C4. C5.)



A4



(C1. C2. C3. C4. C5.)



A5



(C1. C2. C3. C4. C5.)

Accord A,D

*أكورد A, D



A1



(D1. D2. D3. D4. D5.)



A2



(D1. D2. D3. D4. D5.)



A3



(D1. D2. D3. D4. D5.)



A4



(D1. D2. D3. D4. D5.)



A5



(D1. D2. D3. D4. D5.)

Accord B,C

*أكورد B,C



B1



(C1. C2. C3. C4. C5.)



B2



(C1. C2. C3. C4. C5.)



B3



(C1. C2. C3. C4. C5.)



B4



(C1. C2. C3. C4. C5.)



B5



(C1. C2. C3. C4. C5.)

Accord B,D

B,D *أكورد



B1



(D1. D2. D3. D4. D5.)



B2



(D1. D2. D3. D4. D5.)



B3



(D1. D2. D3. D4. D5.)



B4



(D1. D2. D3. D4. D5.)



B5



(D1. D2. D3. D4. D5.)

Accord C,D

*أكورد C,D



C1



(D1. D2. D3. D4. D5.)



C2



(D1. D2. D3. D4. D5.)



C3



(D1. D2. D3. D4. D5.)



C4



(D1. D2. D3. D4. D5.)



C5



(D1. D2. D3. D4. D5.)

الناتج الاجمالي 150 (ACCORD) , (يوجد 30 نتيجة مكررة)

مثل C1B1 هي نفس الأداء، C2B2، و A2B4 هي A1B2، وللتسهيل سنقوم بإلغاء النتائج المكررة.

إذن سيكون الناتج 120 وليس 150 من خلط 4 انواع مختلفة من العائلات العطرية بنسب من 1:5

The total output, 150 (ACCORD) (There are 30 duplicate results)

Like C1B1 is the same performance as C2B2, and A2B4 is A1B2, and for ease, we will cancel the duplicate results.

So the output will be 120, not 150, from mixing 4 different types of aromatic families in ratios of 1:5

Le résultat total, 150 (ACCORD) (Il y a 30 résultats dupliqués)

Comme C1B1 est la même performance que C2B2, et A2B4 est A1B2, pour faciliter les choses, nous allons supprimer les résultats dupliqués.

Donc le résultat sera 120 et non 150 en mélangeant 4 types différents de familles aromatiques dans des proportions de 1:5









































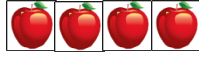







ثالثاً: نتيجة خلط 3 عائلات مختلفة بنسب من 1:5

Troisièmement : Résultat du mélange de 3 familles différentes dans des proportions de 1:5

Troisièmement : Résultat du mélange de 3 familles différentes dans des proportions de 1:5

Accord A,B,C

*أكورد A,B,C





| | | | | | | | | | |
|---|---|---|---|---|---|---|---|---|---|
|  |  |  |  |  |  |  |  |  |  |
| A1 | B1 | (C1. | C2. | C3. | C4. | C5.) | | | |
|  |  |  |  |  |  |  |  |  |  |
| A1 | B2 | (C1. | C2. | C3. | C4. | C5.) | | | |
|  |  |  |  |  |  |  |  |  |  |
| A1 | B3 | (C1. | C2. | C3. | C4. | C5.) | | | |
|  |  |  |  |  |  |  |  |  |  |
| A1 | B4 | (C1. | C2. | C3. | C4. | C5.) | | | |
|  |  |  |  |  |  |  |  |  |  |
| A1 | B5 | (C1. | C2. | C3. | C4. | C5.) | | | |



A2



B1





( **C1.**  **C2.**  **C3.**  **C4.**  **C5.)**

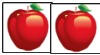

A2

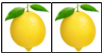

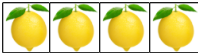
B2





( **C1.**  **C2.**  **C3.**  **C4.**  **C5.)**



A2

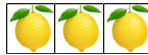

B3

( **C1.**  **C2.**  **C3.**  **C4.**  **C5.)**



A2



B4





( **C1.**  **C2.**  **C3.**  **C4.**  **C5.)**



A2



B5

 **C1.**  **C2.**  **C3.**  **C4.**  **C5.)**



A3



B1

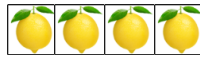

(**C1.** **C2.** **C3.** **C4.** **C5.**)



A3



B2

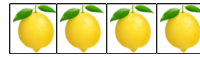
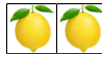

(**C1.** **C2.** **C3.** **C4.** **C5.**)



A3



B3

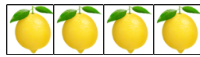
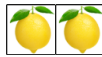

(**C1.** **C2.** **C3.** **C4.** **C5.**)



A3



B4



(**C1.** **C2.** **C3.** **C4.** **C5.**)



A3



B5

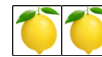

(**C1.** **C2.** **C3.** **C4.** **C5.**)



A4



B1

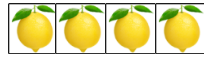

(**C1.** **C2.** **C3.** **C4.** **C5.**)



A4

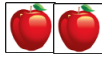

B2



(**C1.** **C2.** **C3.** **C4.** **C5.**)



A4



B3

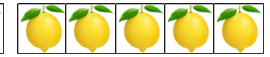
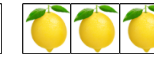

(**C1.** **C2.** **C3.** **C4.** **C5.**)



A4

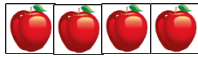

B4



(**C1.** **C2.** **C3.** **C4.** **C5.**)



A4



B5



(**C1.** **C2.** **C3.** **C4.** **C5.**)



A5



B1



(**C1.** **C2.** **C3.** **C4.** **C5.**)



A5



B2

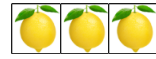

(**C1.** **C2.** **C3.** **C4.** **C5.**)



A5



B3

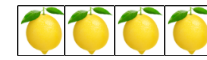
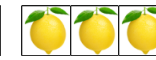

(**C1.** **C2.** **C3.** **C4.** **C5.**)



A5



B4



(**C1.** **C2.** **C3.** **C4.** **C5.**)



A5



B5

































(**C1.** **C2.** **C3.** **C4.** **C5.**)

















Accord A,B,D



















A,B,D أكورد*

 **A1**
  **B1**
 (           )

 **A1**
   **B2**
 (           )

 **A1**
    **B3**
 (           )

 **A1**
     **B4**
 (           )

 **A1**
      **B5**
 (           )



A2



B1



(**D1.** **D2.** **D3.** **D4.** **D5.**)



A2

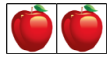

B2



(**D1.** **D2.** **D3.** **D4.** **D5.**)



A2

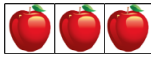

B3



(**D1.** **D2.** **D3.** **D4.** **D5.**)



A2

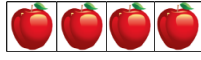

B4



(**D1.** **D2.** **D3.** **D4.** **D5.**)



A2



B5



(**D1.** **D2.** **D3.** **D4.** **D5.**)



A3



B1

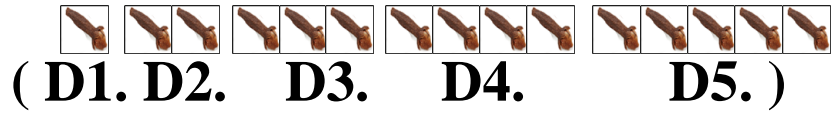

(**D1. D2. D3. D4. D5.**)



A3

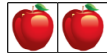

B2

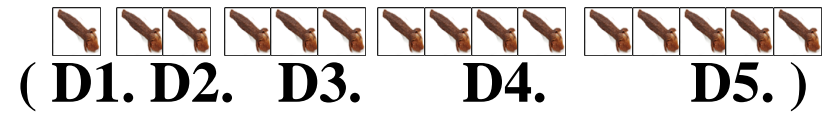

(**D1. D2. D3. D4. D5.**)



A3

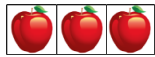

B3



(**D1. D2. D3. D4. D5.**)



A3

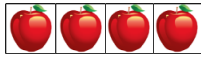

B4

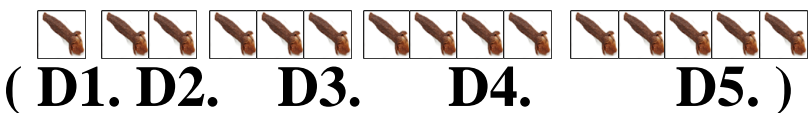

(**D1. D2. D3. D4. D5.**)



A3

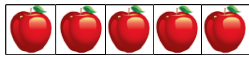

B5

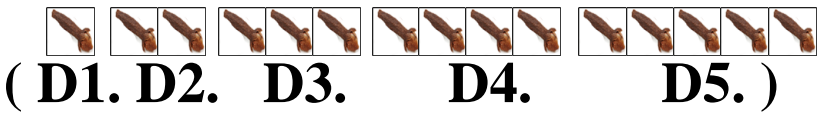

(**D1. D2. D3. D4. D5.**)



A4



B1



(**D1.** **D2.** **D3.** **D4.** **D5.**)



A4

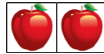

B2



(**D1.** **D2.** **D3.** **D4.** **D5.**)



A4

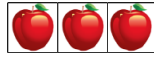

B3



(**D1.** **D2.** **D3.** **D4.** **D5.**)



A4

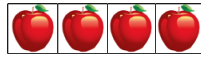

B4



(**D1.** **D2.** **D3.** **D4.** **D5.**)



A4

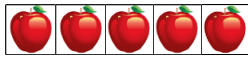

B5



(**D1.** **D2.** **D3.** **D4.** **D5.**)



A5



B1



(**D1. D2. D3. D4. D5.**)



A5

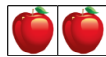

B2



(**D1. D2. D3. D4. D5.**)



A5

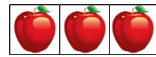

B3



(**D1. D2. D3. D4. D5.**)



A5

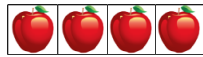

B4



(**D1. D2. D3. D4. D5.**)



A5



B5



(**D1. D2. D3. D4. D5.**)

Accord A,C,D

*أكورد A,C,D



A1



C1

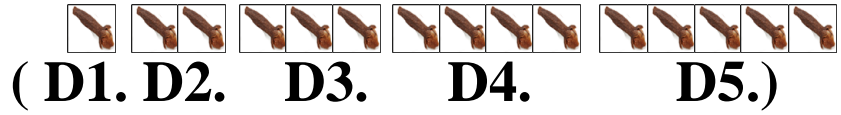

A1

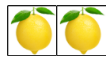

C2

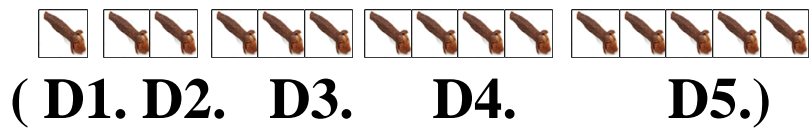

A1



C3

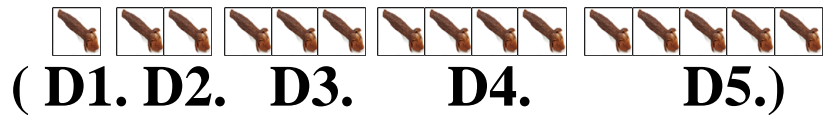

A1



C4

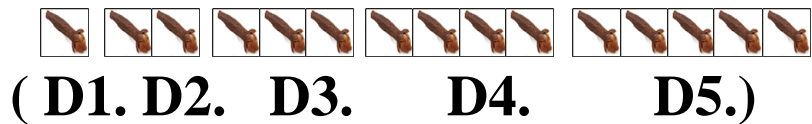

A1



C5

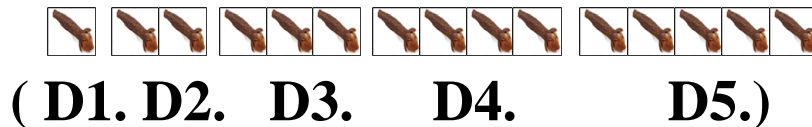



A2



C1

(    )

(D1. D2. D3. D4. D5.)



A2

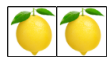

C2

(    )

(D1. D2. D3. D4. D5.)



A2



C3

(    )

(D1. D2. D3. D4. D5.)



A2



C4

(    )

(D1. D2. D3. D4. D5.)



A2



C5

(    )

(D1. D2. D3. D4. D5.)



A3



C1



(**D1. D2. D3. D4. D5.**)



A3

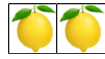

C2



(**D1. D2. D3. D4. D5.**)



A3



C3



(**D1. D2. D3. D4. D5.**)



A3



C4



(**D1. D2. D3. D4. D5.**)



A3



C5



(**D1. D2. D3. D4. D5.**)



A4



C1

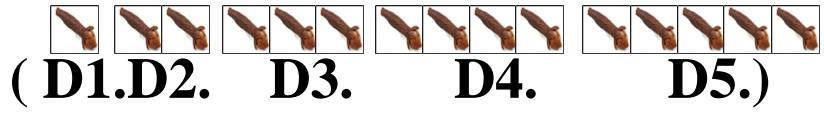

(**D1.** **D2.** **D3.** **D4.** **D5.**)



A4



C2



(**D1.** **D2.** **D3.** **D4.** **D5.**)



A4

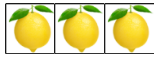

C3



(**D1.** **D2.** **D3.** **D4.** **D5.**)



A4

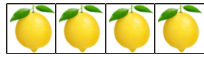

C4



(**D1.** **D2.** **D3.** **D4.** **D5.**)



A4



C5



(**D1.** **D2.** **D3.** **D4.** **D5.**)



A5



C1



(**D1. D2. D3. D4. D5.**)



A5

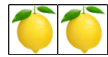

C2



(**D1. D2. D3. D4. D5.**)



A5



C3



(**D1. D2. D3. D4. D5.**)



A5

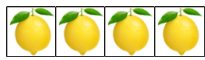

C4



(**D1. D2. D3. D4. D5.**)



A5



C5



(**D1. D2. D3. D4. D5.**)

Accord B,C,D

*أكورد B,C,D















































B1 **C1** (**D1. D2. D3. D4. D5.**)





















B1 **C2** (**D1. D2. D3. D4. D5.**)

B1 **C3** (**D1. D2. D3. D4. D5.**)





















B1 **C4** (**D1. D2. D3. D4. D5.**)

















B1 **C5** (**D1. D2. D3. D4. D5.**)



B2



C1



(**D1.** **D2.** **D3.** **D4.** **D5.**)



B2

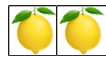

C2



(**D1.** **D2.** **D3.** **D4.** **D5.**)



B2



C3



(**D1.** **D2.** **D3.** **D4.** **D5.**)



B2



C4



(**D1.** **D2.** **D3.** **D4.** **D5.**)



B2



C5



(**D1.** **D2.** **D3.** **D4.** **D5.**)

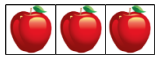

B3



C1



(**D1. D2. D3. D4. D5.**)



B3



C2



(**D1. D2. D3. D4. D5.**)



B3

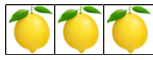

C3



(**D1. D2. D3. D4. D5.**)

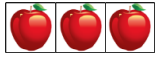

B3

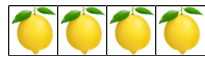

C4



(**D1. D2. D3. D4. D5.**)



B3



C5



(**D1. D2. D3. D4. D5.**)

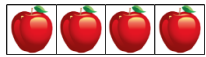

B4



C1



(**D1. D2. D3. D4. D5.**)

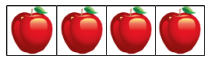

B4



C2



(**D1. D2. D3. D4. D5.**)



B4



C3



(**D1. D2. D3. D4. D5.**)



B4



C4



(**D1. D2. D3. D4. D5.**)



B4



C5



(**D1. D2. D3. D4. D5.**)



B5



C1



(D1.D2. D3. D4. D5.)



B5



C2



(D1. D2. D3. D4. D5.)

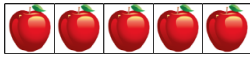

B5

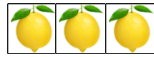

C3



(D1. D2. D3. D4. D5.)

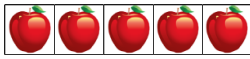

B5



C4



(D1. D2. D3. D4. D5.)

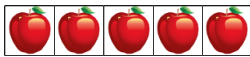

B5



C5

(D1. D2. D3. D4. D5.)

والواضح من الناتج هو عدد 500 منهم 40 نتيجة مكررة، أكورد أو فورميولا.

****ملحوظة:**

قد نصل إلى بعض النتائج المتشابهة بأرقام مختلفة ولكن بإعداد قليلة يمكن تجاهلها
مثل A2C1B1 تتشابه مع A4C2B2

And it is clear from the result that the number is 500, including 40 duplicate results, Accord or Formula.

**** Note:** We may reach some similar results with different numbers but with few settings that can be ignored, such as A2C1B1 is similar to A4C2B2















Et il est clair d'après le résultat qu'il y a 500, dont 40 résultats en double, Accord ou Formula.

















**** Remarque :** Il est possible d'arriver à des résultats similaires avec des chiffres différents, mais avec quelques réglages négligeables, comme A2C1B1, qui est similaire à A4C2B2

















رابعاً:- نتاج أكورد يتكون من 4 عائلات عطرية A,B,C,D بنسب من 1: 5 وتكون النتيجة 625 فورميولا. منهم 18 نتاج مكررة (والطريقة سهلة جداً) سنأخذ الاكوردات الناتجة من خلط B,C,D ونضيف عليها A وهكذا



















Fourthly:- Accord results consisting of 4 aromatic families A, B, C, D in ratios of 1:5, resulting in 625 formulas. Among them are 18 duplicate results (and the method is very easy). We will take the resulting accords from mixing B, C, and D, and add A to them like this:



















Quatrièmement :- Résultats Accord composé de 4 familles olfactives A, B, C, D dans des proportions de 1 : 5 et le résultat est de 625 formules. Parmi eux, 18 résultats sont dupliqués (et la méthode est très simple) Nous prendrons les accords résultant du mélange de B, C, D et nous y ajouterons A comme ceci

   (           )
A1 [B1 C1 (D1. D2. D3. D4. D5.)]

    (           )
A1 [B1 C2 (D1. D2. D3. D4. D5.)]

     (           )
A1 [B1 C3 (D1. D2. D3. D4. D5.)]

      (           )
A1 [B1 C4 (D1. D2. D3. D4. D5.)]

       (           )
A1 [B1 C5 (D1.D2. D3. D4. D5.)]































A1 [B2 C1 (D1. D2. D3. D4. D5.)]



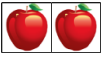













A1 [B2 C2 (D1. D2. D3. D4. D5.)]













A1 [B2 C3 (D1. D2. D3. D4. D5.)]















A1 [B2 C4 (D1. D2. D3. D4. D5.)]

















A1 [B2 C5 (D1. D2. D3. D4. D5.)]



A1 [B3



C1



(D1. D2. D3. D4. D5.)]

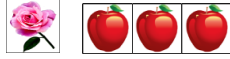

A1 [B3

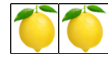

C2



(D1. D2. D3. D4. D5.)]



A1 [B3



C3



(D1. D2. D3. D4. D5.)]

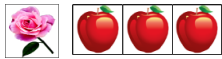

A1 [B3



C4



(D1. D2. D3. D4. D5.)]







A1 [B3



C5

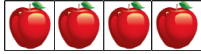

(D1. D2. D3. D4. D5.)]



A1 [B4

C1

(D1. D2. D3. D4.

D5.)]



A1 [B4

C2

(D1. D2. D3. D4.

D5.)]



A1 [B4

C3

(D1. D2. D3. D4.

D5.)]







A1 [B4

C4

(D1. D2. D3. D4.

D5.)]



A1 [B4

C5

(D1. D2. D3. D4.

D5.)]



A1 [B5



C1



(D1. D2. D3. D4. D5.)]



A1 [B5

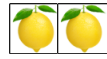

C2



(D1. D2. D3. D4. D5.)]



A1 [B5

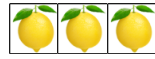

C3



(D1. D2. D3. D4. D5.)]

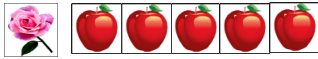

A1 [B5



C4



(D1. D2. D3. D4. D5.)]



A1 [B5

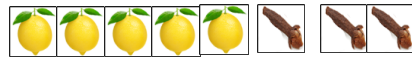

C5



(D1. D2. D3. D4. D5.)]



A2 [B1



C1



(D1. D2. D3. D4. D5.)]



A2 [B1



C2



(D1. D2. D3. D4. D5.)]



A2 [B1



C3



(D1. D2. D3. D4. D5.)]



A2 [B1



C4



(D1. D2. D3. D4. D5.)]



A2 [B1



C5



(D1. D2. D3. D4. D5.)]



A2 [B2



C1



(D1. D2. D3. D4. D5.)]



A2 [B2



C2



(D1. D2. D3. D4. D5.)]



A2 [B2



C3



(D1. D2. D3. D4. D5.)]



A2 [B2

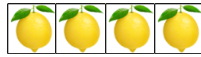

C4



(D1. D2. D3. D4. D5.)]



A2 [B2



C5



(D1. D2. D3. D4. D5.)]

















A2 [B3 C1 (D1. D2. D3. D4. D5.)]











A2 [B3 C2 (D1. D2. D3. D4. D5.)]

















A2 [B3 C3 (D1. D2. D3. D4. D5.)]



















A2 [B3 C4 (D1. D2. D3. D4. D5.)]











A2 [B3 C5 (D1. D2. D3. D4. D5.)]





A2 [B4 C1 (D1. D2. D3. D4. D5.)]





A2 [B4 C2 (D1. D2. D3. D4. D5.)]





A2 [B4 C3 (D1. D2. D3. D4. D5.)]









A2 [B4 C4 (D1. D2. D3. D4. D5.)]













A2 [B4 C5 (D1. D2. D3. D4. D5.)]





A2 [B5 C1 (D1. D2. D3. D4. D5.)]





A2 [B5 C2 (D1. D2. D3. D4. D5.)]









A2 [B5 C3 (D1. D2. D3. D4. D5.)]









A2 [B5 C4 (D1. D2. D3. D4. D5.)]









A2 [B5 C5 (D1. D2. D3. D4. D5.)]



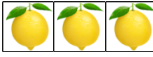





A3 [B1 C1 (D1. D2. D3. D4. D5.)]



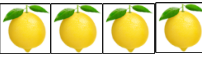





A3 [B1 C2 (D1. D2. D3. D4. D5.)]

A3 [B1 C3 (D1. D2. D3. D4. D5.)]

A3 [B1 C4 (D1. D2. D3. D4. D5.)]

A3 [B1 C5 (D1. D2. D3. D4. D5.)]











A3 [B2 C1 (D1. D2. D3. D4. D5.)]











A3 [B2 C2 (D1. D2. D3. D4. D5.)]











A3 [B2 C3 (D1. D2. D3. D4. D5.)]











A3 [B2 C4 (D1. D2. D3. D4. D5.)]











A3 [B2 C5 (D1. D2. D3. D4. D5.)]



A3 [B3



C1



(D1. D2. D3. D4. D5.)]



A3 [B3

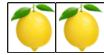

C2



(D1. D2. D3. D4. D5.)]



A3 [B3



C3



(D1. D2. D3. D4. D5.)]



A3 [B3

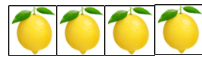

C4



(D1. D2. D3. D4. D5.)]

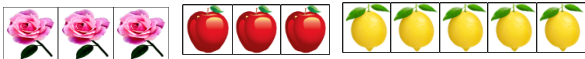

A3 [B3

C5



(D1. D2. D3. D4. D5.)]



A3 [B4



C1



(D1. D2. D3. D4. D5.)]



A3 [B4



C2



(D1. D2. D3. D4. D5.)]



A3 [B4



C3



(D1. D2. D3. D4. D5.)]



A3 [B4



C4



(D1. D2. D3. D4. D5.)]

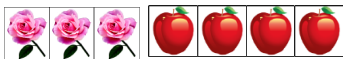















A3 [B4

















C5

















(D1. D2. D3. D4. D5.)]















A3 [B5 C1 (D1. D2. D3. D4. D5.)]















A3 [B5 C2 (D1. D2. D3. D4. D5.)]





A3 [B5 C3 (D1. D2. D3. D4. D5.)]





A3 [B5 C4 (D1. D2. D3. D4. D5.)]





A3 [B5 C5 (D1. D2. D3. D4. D5.)]





A4 [B1 C1 (D1. D2. D3. D4. D5.)]





A4 [B1 C2 (D1. D2. D3. D4. D5.)]





A4 [B1 C3 (D1. D2. D3. D4. D5.)]





A4 [B1 C4 (D1. D2. D3. D4. D5.)]

A4 [B1 C5 (D1. D2. D3. D4. D5.)]

A4 [B2 C1 (D1. D2. D3. D4. D5.)]









A4 [B2 C2 (D1. D2. D3. D4. D5.)]













A4 [B2 C3 (D1. D2. D3. D4. D5.)]



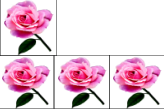

A4 [B2 C4 (D1. D2. D3. D4. D5.)]



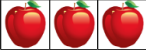

A4 [B2 C5 (D1. D2. D3. D4. D5.)]



A4 [B3 C1 (D1. D2. D3. D4. D5.)]



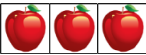
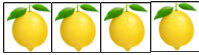

A4 [B3 C2 (D1. D2. D3. D4. D5.)]

A4 [B3 C3 (D1. D2. D3. D4. D5.)]







A4 [B3 C4 (D1. D2. D3. D4. D5.)]

A4 [B3 C5 (D1. D2. D3. D4. D5.)]









A4 [B4 C1 (D1. D2. D3. D4. D5.)]





A4 [B4 C2 (D1. D2. D3. D4. D5.)]

A4 [B4 C3 (D1. D2. D3. D4. D5.)]





A4 [B4 C4 (D1. D2. D3. D4. D5.)]





A4 [B4 C5 (D1. D2. D3. D4. D5.)]

A4 [**B5** **C1** (**D1. D2. D3. D4. D5.**)]



A4 [**B5** **C2** (**D1. D2. D3. D4. D5.**)]

A4 [**B5** **C3** (**D1. D2. D3. D4. D5.**)]

A4 [**B5** **C4** (**D1. D2. D3. D4. D5.**)]



A4 [**B5** **C5** (**D1.D2. D3. D4. D5.**)]



















A5 [B1 C1 (D1. D2. D3. D4. D5.)]



















A5 [B1 C2 (D1. D2. D3. D4. D5.)]







A5 [B1 C3 (D1. D2. D3. D4. D5.)]



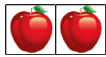





A5 [B1 C4 (D1. D2. D3. D4. D5.)]







A5 [B1 C5 (D1. D2. D3. D4. D5.)]



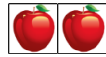





A5 [B2 C1 (D1. D2. D3. D4. D5.)]









A5 [B2 C2 (D1. D2. D3. D4. D5.)]





A5 [B2 C3 (D1. D2. D3. D4. D5.)]











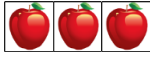





A5 [B2 C4 (D1. D2. D3. D4. D5.)]







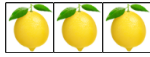



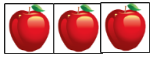



A5 [B2 C5 (D1. D2. D3. D4. D5.)]







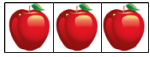





































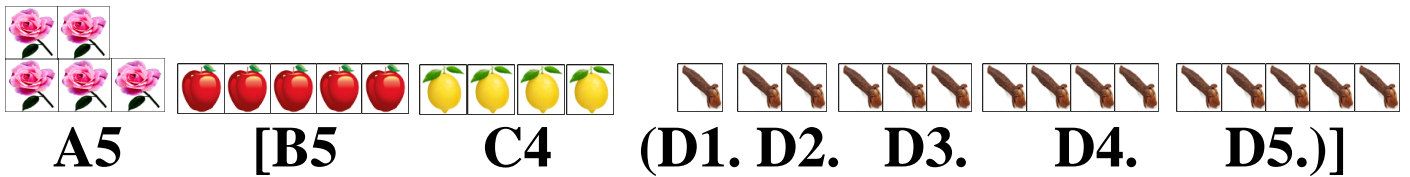
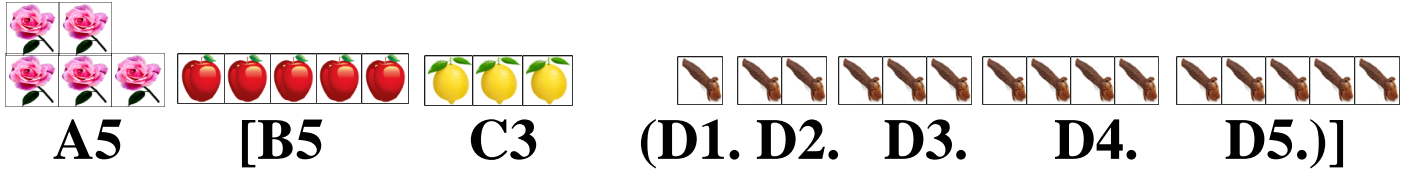
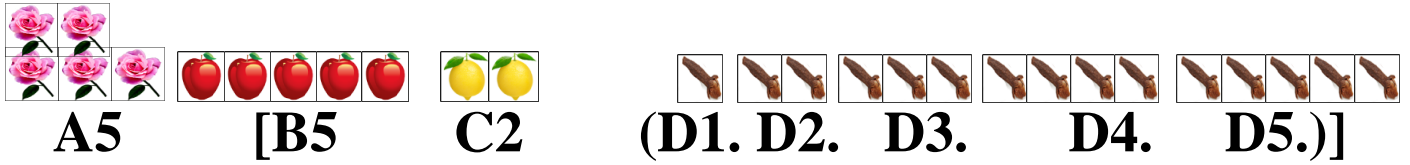
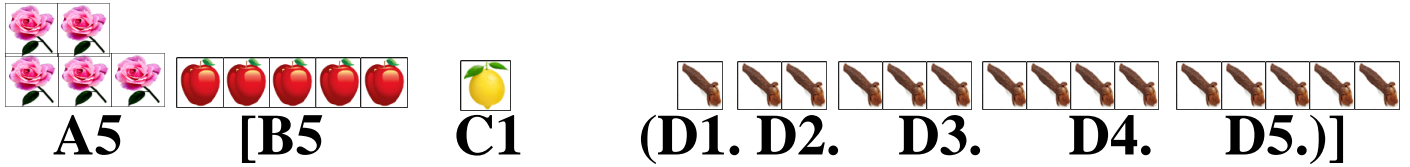

****ملحوظة بسيطة جداً:**

A2B1C1 هي نفس النتيجة لـ A4B2C2 ، وأن A4B4C2 هي نفس النتيجة لـ A2B2C1 وهي أعداد بسيطة يمكن تجاهلها

**و سنترك لك أيها المتدرب استخراج الأكوردات المكررة تدريب لك .

خامساً :- أكوردات يتكون من 5 عائلات عطرية سيتم شرحه بالتفصيل لاحقاً

****ملحوظة:** إن العلامة الموجودة تحت أي حرف على سبيل المثال A تدل أنه مكرر يمكن حذفه

**** A very simple note:** A2B1C1 is the same result as A4B2C2, and A4B4C2 is the same result as A2B2C1, which are simple numbers that can be ignored.

** And we will leave it to you, the trainee, to extract the repeated chords as an exercise for you.

Fifth: - Chords consisting of 5 aromatic families will be explained in detail later.

**** Note:** The mark below any letter, for example, A, indicates that it is repeated and can be deleted.

**** Remarque très simple :** A2B1C1 est le même résultat que A4B2C2, et A4B4C2 est le même résultat que A2B2C1, ce sont des nombres simples qui peuvent être ignorés.

** Et nous vous laisserons, cher stagiaire, extraire les accords répétés, comme exercice pour vous.

Cinquièmement :- Accords composés de 5 familles aromatiques qui seront expliquées en détail plus tard.

**** Remarque :** le symbole sous n'importe quelle lettre, par exemple A, indique qu'elle est répétée et peut être supprimée.

التمثيل البيانات للأكوردات

Data representation for chords

Représentation des données pour les accords

Accord A, B

***أكورد A, B**

1



A1B1

2



A1B2

3



A1B3

4

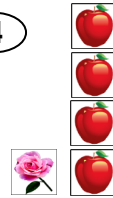

A1B4

5



A1B5

6



A2B1

7



A2B2

8

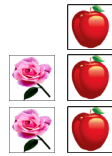

A2B3

9



A2B4

10

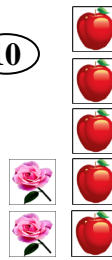

A2B5

11

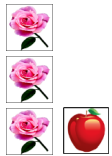

A3B1

12

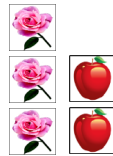

A3B2

13



A3B3

14



A3B4

15

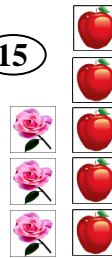

A3B5

16



A4B1

17



A4B2

18



A4B3

19



A4B4

20



A4B5

21



A5B1

22



A5B2

23



A5 B3

24



A5B4

25



A5B5

Accord A, C

*أكورد A,C

26



A1C1

27

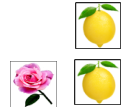

A1C2

28

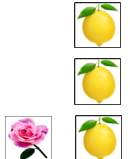

A1C3

29



A1C4

30

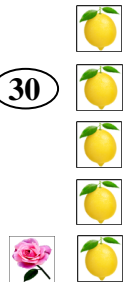

A1C5

31

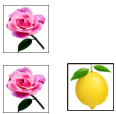

A2C1

32



A2C2

33

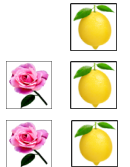

A2C3

34

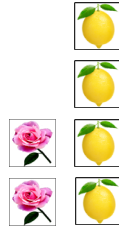

A2C4

35

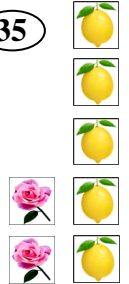

A2C5

36

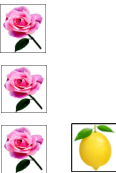

A3C1

37



A3C2

38

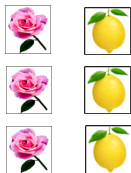

A3 C3

39



A3C4

40

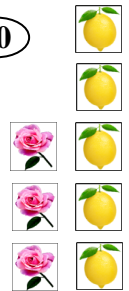

A3C5

41



A4C1

42



A4C2

43

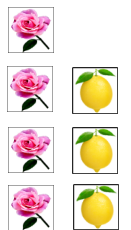

A4C3

44



A4C4

45

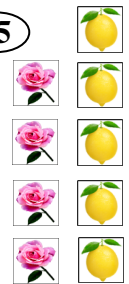

A4C5

46



A5C1

47



A5C2

48

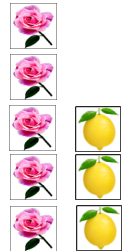

A5C3

49

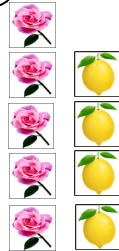

A5C4

50

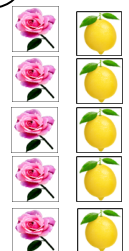

A5C5

Accord A, D

*أكورد A, D

51



A1D1

52



A1D2

53



A1D3

54

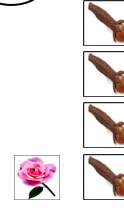

A1D4

55



A1D5

56



A2D1

57



A2D2

58



A2D3

59



A2D4

60



A2D5

61



A3D1

62



A3D2

63



A3D3

64



A3D4

65



A3D5

66



A4D1

67



A4D2

68



A4D3

69



A4D4

70



A4D5

71



A5D1

72



A5D2

73



A5D3

74



A5D4

75



A5D5

Accord B, C

B, C *أكورد

76



B1C1

77

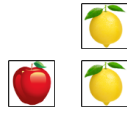

B1C2

78

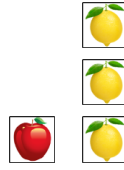

B1C3

79



B1C4

80

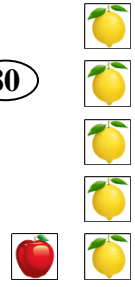

B1C5

81

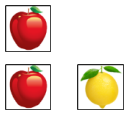

B2C1

82



B2C2

83

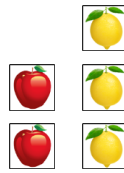

B2C3

84



B2C4

85

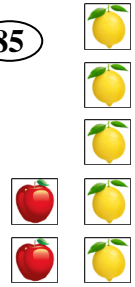

B2C5

86

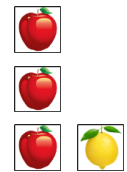

B3C1

87



B3C2

88

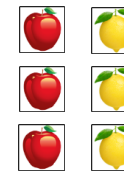

B3C3

89



B3C4

90

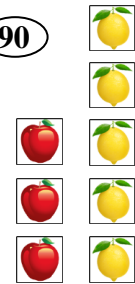

B3C5

91



B4C1

92

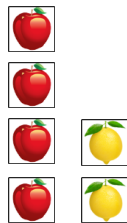

B4C2

93



B4C3

94



B4C4

95

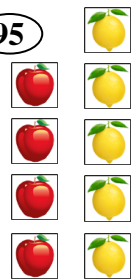

B4C5

96

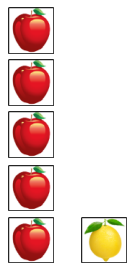

B5C1

97

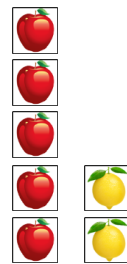

B5C2

98



B5C3

99



B5C4

100

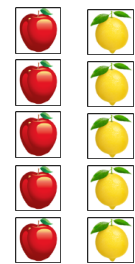

B5C5

Accord B,D

B,D أكورد*

101



B1D1

102



B1D2

103

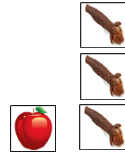

B1D3

104



B1D4

105

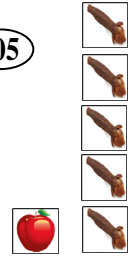

B1D5

106

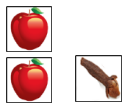

B2D1

107



B2D2

108

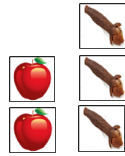

B2D3

109

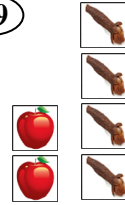

B2D4

110



B2D5

111

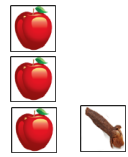

B3D1

112

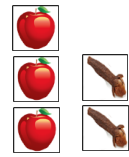

B3D2

113

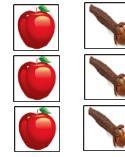

B3D3

114



B3D4

115

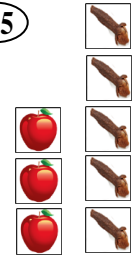

B3D5

116

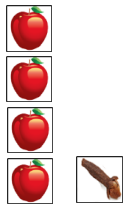

B4D1

117

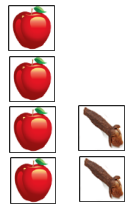

B4D2

118



B4D3

119



B4D4

120

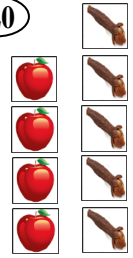

B4D5

121

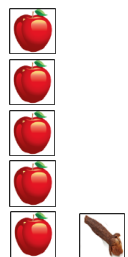

B5D1

122

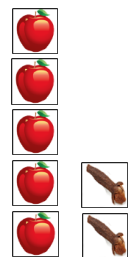

B5D2

123

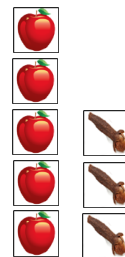

B5D3

124

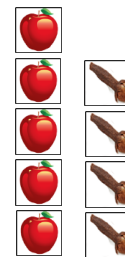

B5D4

125

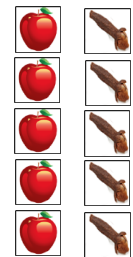

B5D5

Accord C,D

C,D أكوارد

126



C1D1

127

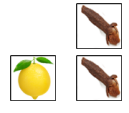

C1D2

128

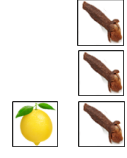

C1D3

129

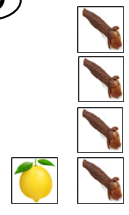

C1D4

130



C1D5

131

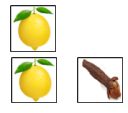

C2D1

132

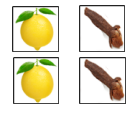

C2D2

133

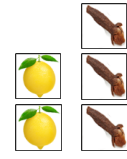

C2D3

134

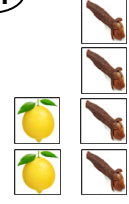

C2D4

135



C2D5

136

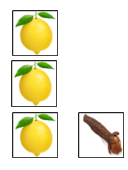

C3D1

137

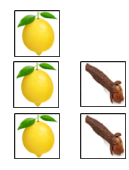

C3D2

138



C3D3

139

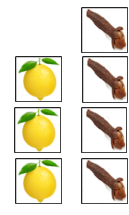

C3D4

140



C3D5

141



C4D1

142



C4D2

143



C4D3

144

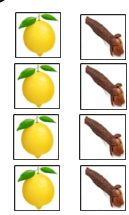

C4D4

145



C4D5

146

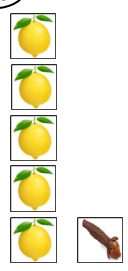

C5D1

147

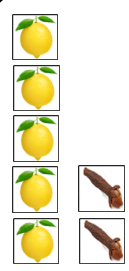

C5D2

148



C5D3

149

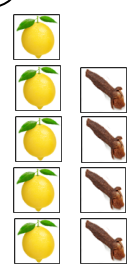

C5D4

150



C5D5

Accord A,B,C

A,B,C أكورد*

151



A1B1C1

152



A1B1C2

153

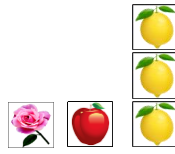

A1B1C3

154

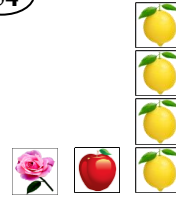

A1B1C4

155

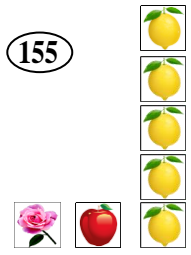

A1B1C5

156



A1B2C1

157



A1 B2 C2

158

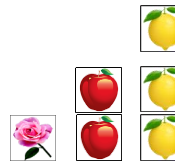

A1B2 C3

159

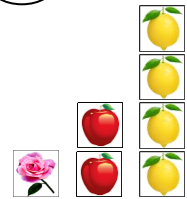

A1B2 C4

160

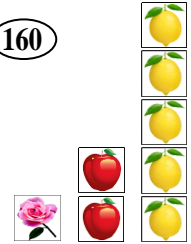

A1B2 C5

161

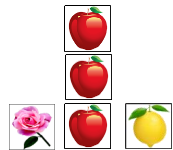

A1B3C1

162

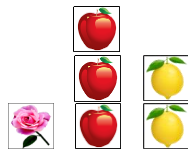

A1B3C2

163

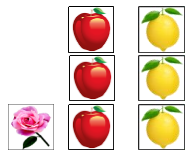

A1B3C3

164

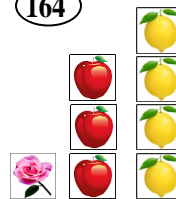

A1B3C4

165

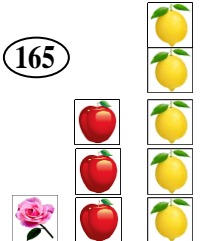

A1B3C5

166

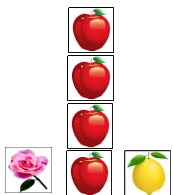

A1B4C1

167

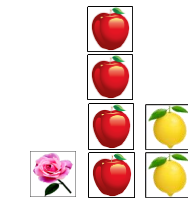

A1B4C2

168

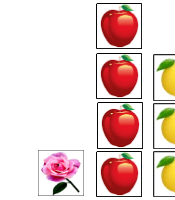

A1B4C3

169

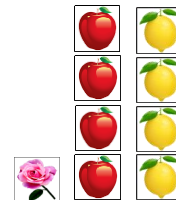

A1B4C4

170

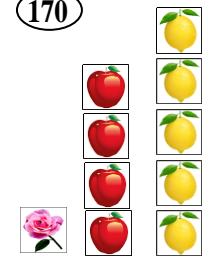

A1B4C5

171

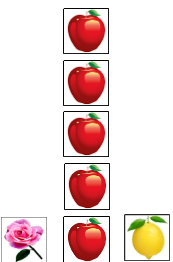

A1B5C1

172

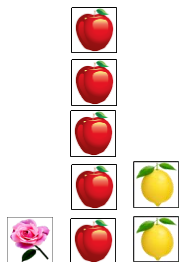

A1B5C2

173

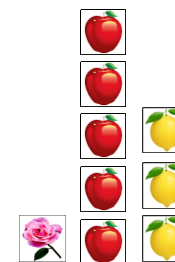

A1B5C3

174

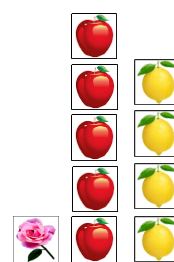

A1B5C4

175

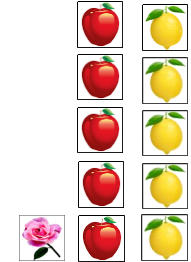

A1B5C5

176



A2B1C1

177



A2B1C2

178

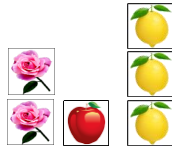

A2B1C3

179

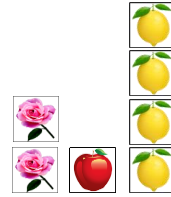

A2B1C4

180

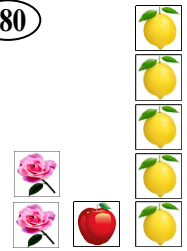

A2B1C5

181



A2B2C1

182



A2B2C2

183



A2B2C3

184

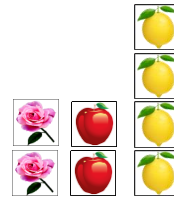

A2B2C4

185

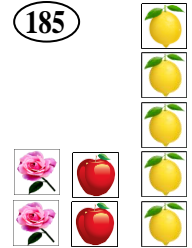

A2B2C5

186

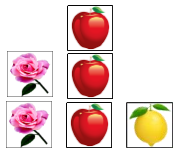

A2B3C1

187

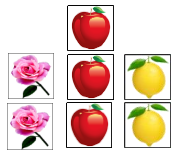

A2B3C2

188

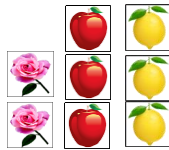

A2B3C3

189

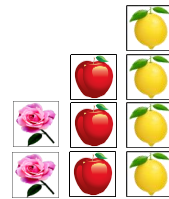

A2B3C4

190

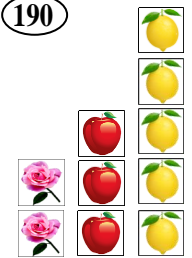

A2B3C5

191

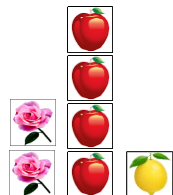

A2B4C1

192

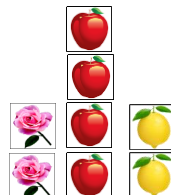

A2B4C2

193

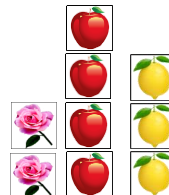

A2B4C3

194

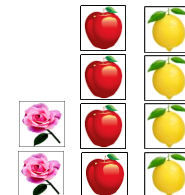

A2B4C4

195

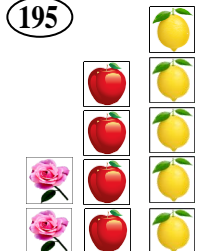

A2B4C5

196

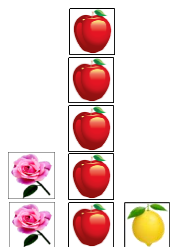

A2B5C1

197

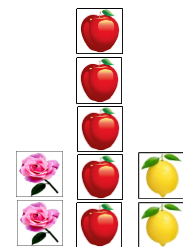

A2B5C2

198

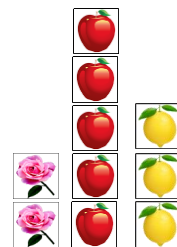

A2B5C3

199

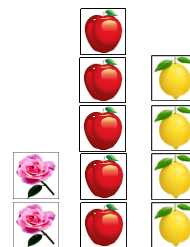

A2B5C4

200

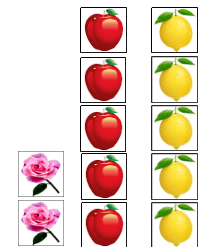

A2B5C5

201

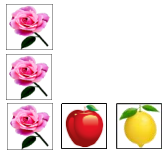

A3B1C1

202

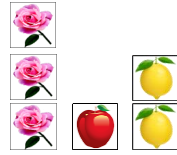

A3B1C2

203

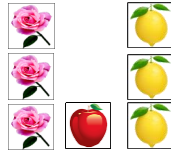

A3B1C3

204

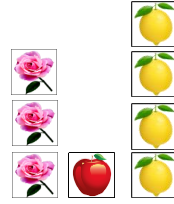

A3B1C4

205

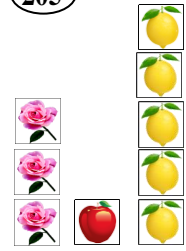

A3B1C5

206

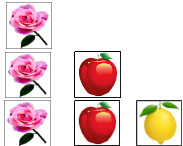

A3B2C1

207

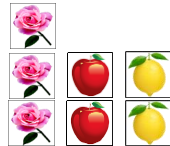

A3B2C2

208

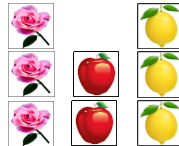

A3B2C3

209

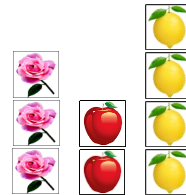

A3B2C4

210

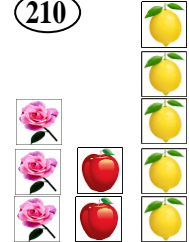

A3B2C5

211

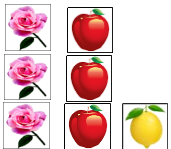

A3B3C1

212

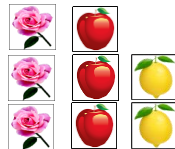

A3B3C2

213



A3B3C3

214

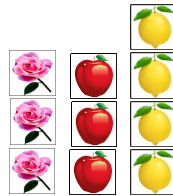

A3B3C4

215

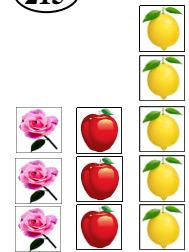

A3B3C5

216

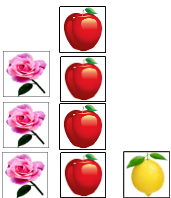

A3B4C1

217

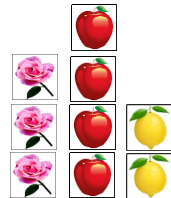

A3B4C2

218

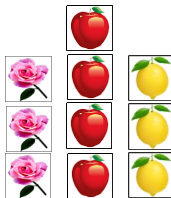

A3B4C3

219

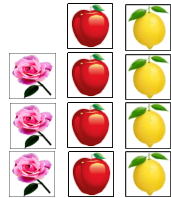

A3B4C4

220

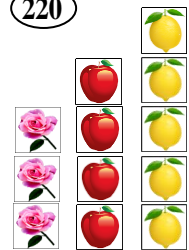

A3B4C5

221

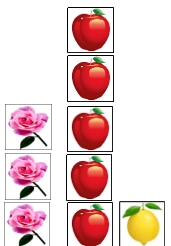

A3B5C1

222

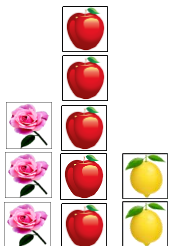

A3B5C2

223

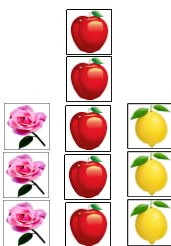

A3B5C3

224

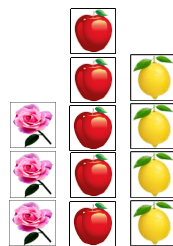

A3B5C4

225

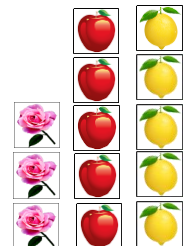

A3B5C5

226

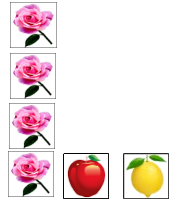

A4B1C1

227

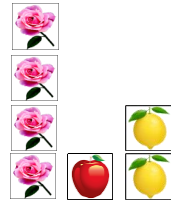

A4B1C2

228

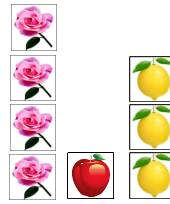

A4B1C3

229

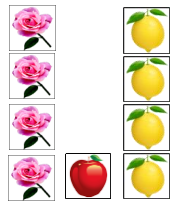

A4B1C4

230

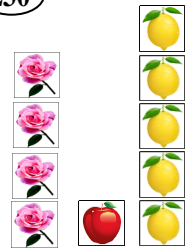

A4 B1C5

231

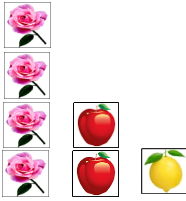

A4B2C1

232

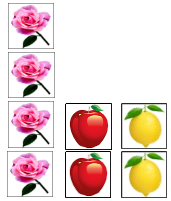

A4B2C2

233

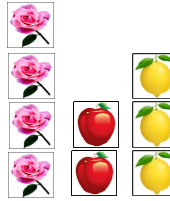

A4B2C3

234

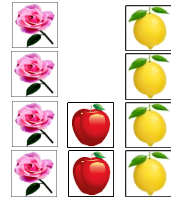

A4B2C4

235

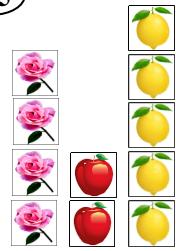

A4B2C5

236

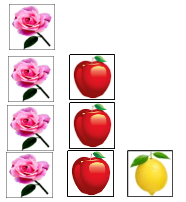

A4B3C1

237

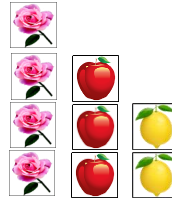

A4B3C2

238

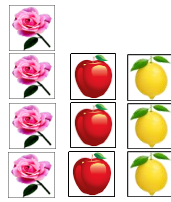

A4B3C3

239



A4B3C4

240

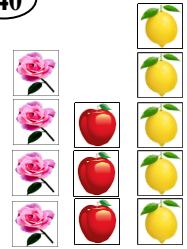

A4B3C5

241

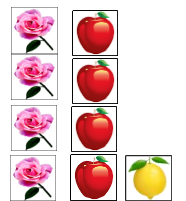

A4B4C1

242

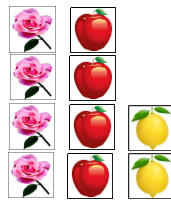

A4B4C2

243

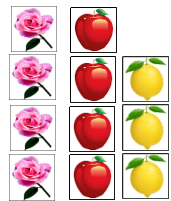

A4B4C3

244

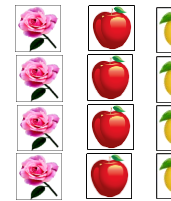

A4B4C4

245

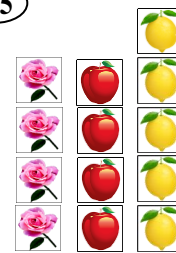

A4B4C5

246

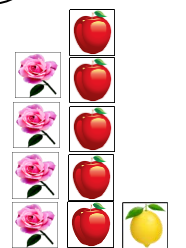

A4B5C1

247

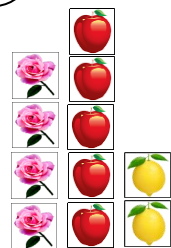

A4B5C2

248

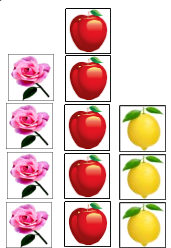

A4B5C3

249

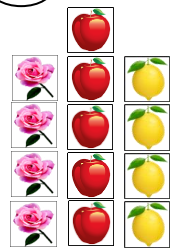

A4B5C4

250

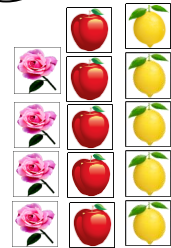

A4B5C5

251

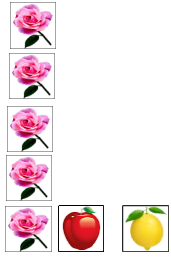

A5B1C1

252

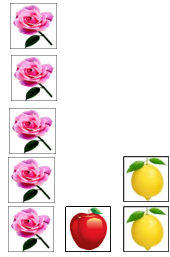

A5B1C2

253

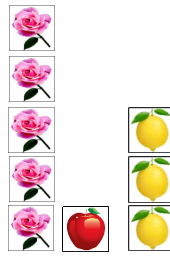

A5B1C3

254

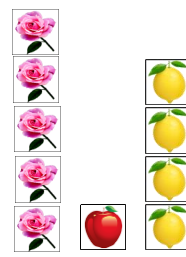

A5B1C4

255

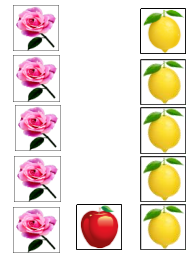

A5B1C5

256

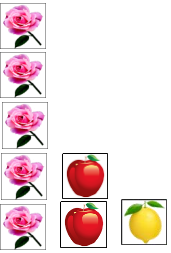

A5B2C1

257

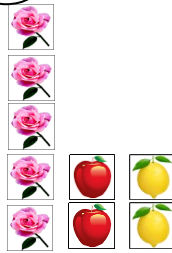

A5B2C2

258

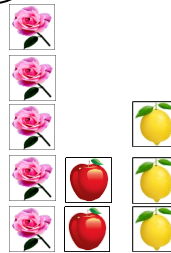

A5B2C3

259

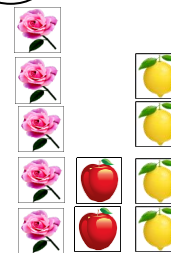

A5B2C4

260

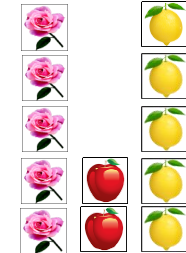

A5B2C5

261

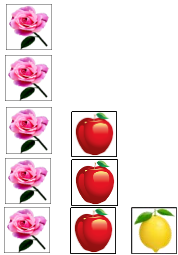

A5B3C1

262

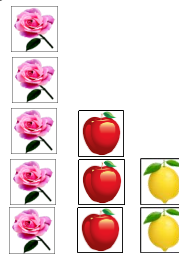

A5B3C2

263

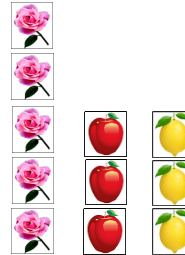

A5B3C3

264



A5B3C4

265

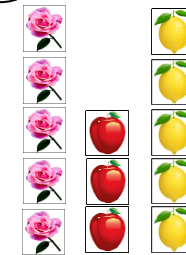

A5B3C5

266

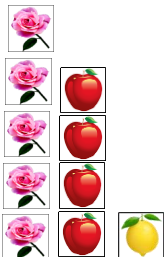

A5B4C1

267

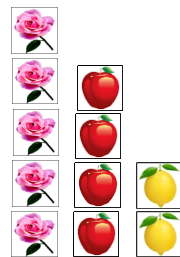

A5B4C2

268

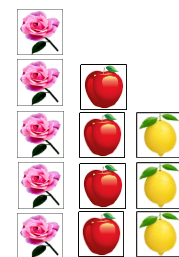

A5B4C3

269

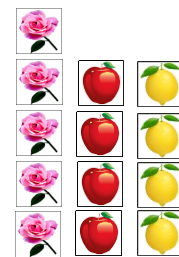

A5B4C4

270

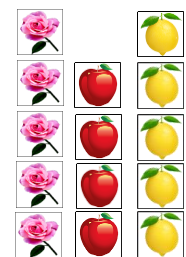

A5B4C5

271

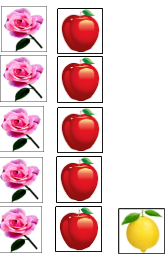

A5B5C1

272

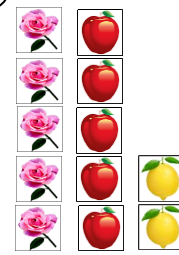

A5B5C2

273

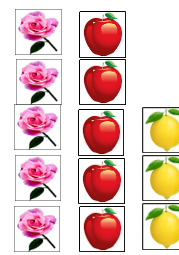

A5B5C3

274

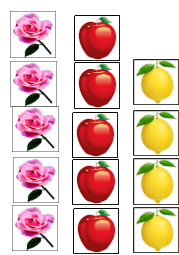

A5B5C4

275

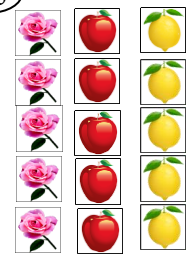

A5B5C5

Accord A,B,D

*أكورد A,B,D

276



A1B1D1

277



A1B1D2

278

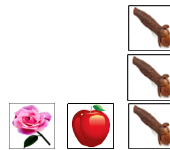

A1B1D3

279

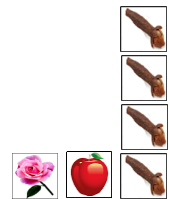

A1B1D4

280



A1B1D5

281



A1B2D1

282



A1B2D2

283

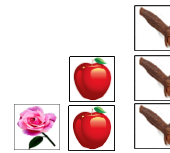

A1B2D3

284

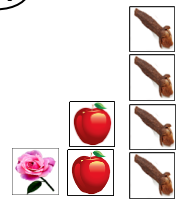

A1B2D4

285

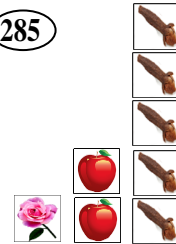

A1B2D5

286

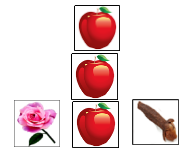

A1B3D1

287

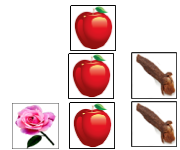

A1B3D2

288

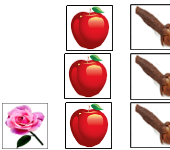

A1B3D3

289

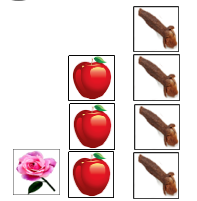

A1B3D4

290

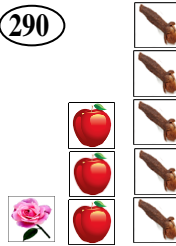

A1B3D5

291

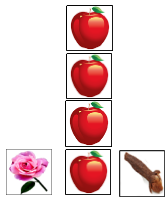

A1B4D1

292

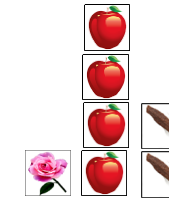

A1B4D2

293

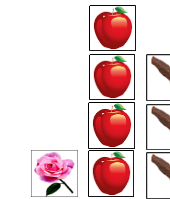

A1B4D3

294

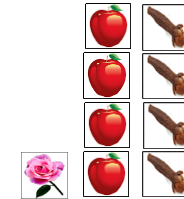

A1B4D4

295

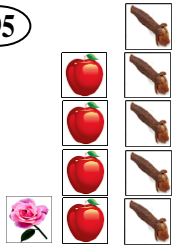

A1B4D5

296

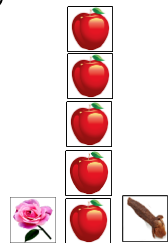

A1B5D1

297

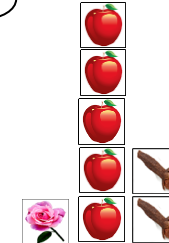

A1B5D2

298

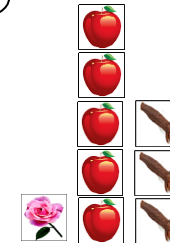

A1B5D3

299

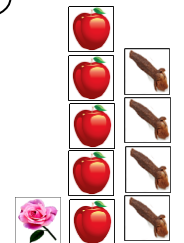

A1B5D4

300

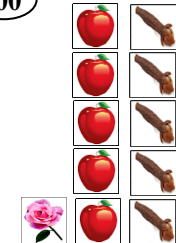

A1B5D5

301

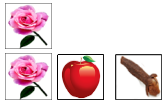

A2B1D1

302

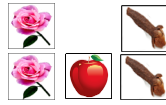

A2B1D2

303

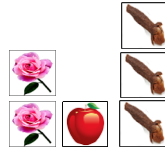

A2B1D3

304

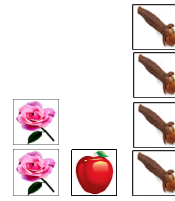

A2B1D4

305

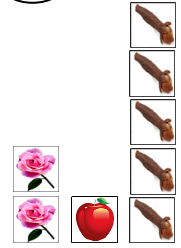

A2B1D5

306



A2B2D1

307



A2B2D2

308

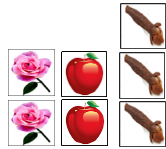

A2B2D3

309

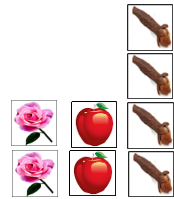

A2B2D4

310

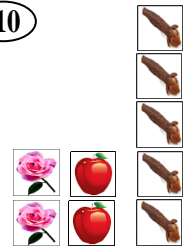

A2B2D5

311

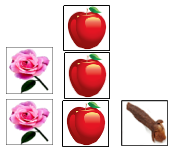

A2B3D1

312

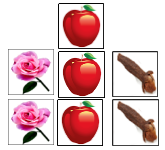

A2B3D2

313

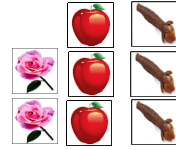

A2B3D3

314

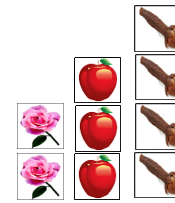

A2B3D4

315

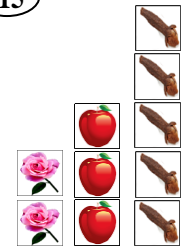

A2B3D5

316

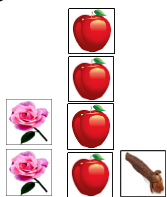

A2B4D1

317

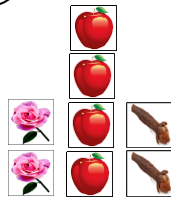

A2B4D2

318

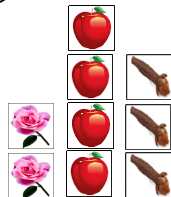

A2B4D3

319

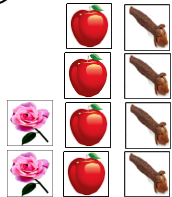

A2B4D4

320

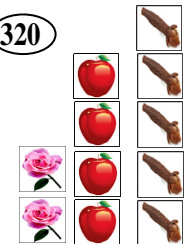

A2B4D5

321

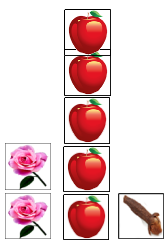

A2B5D1

322

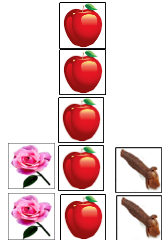

A2B5D2

323

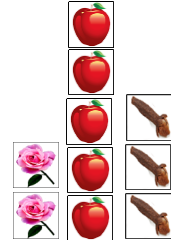

A2B5D3

324

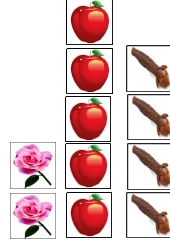

A2B5D4

325

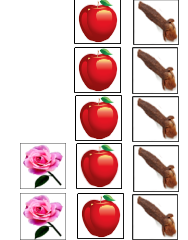

A2B5D5

326

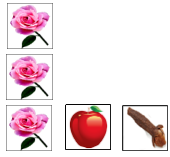

A3B1D1

327

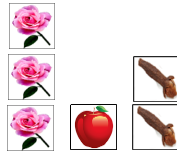

A3 B1D2

328

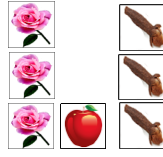

A3B1D3

329

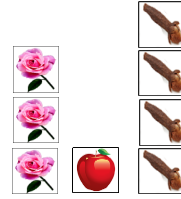

A3B1D4

330

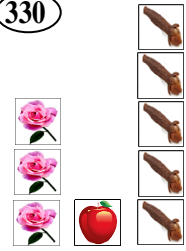

A3B1D5

331

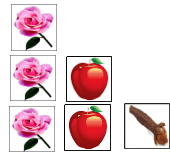

A3B2D1

332

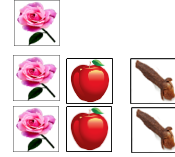

A3B2D2

333

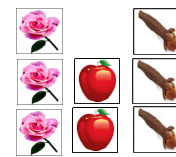

A3B2D3

334

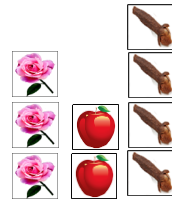

A3B2D4

335

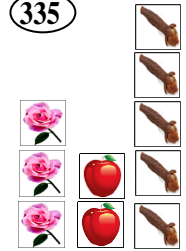

A3B2D5

336

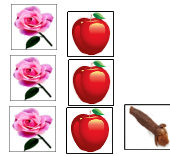

A3B3D1

337

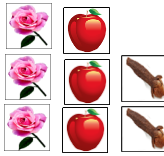

A3B3D2

338

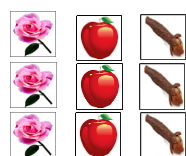

A3B3D3

339

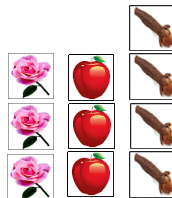

A3B3D4

340

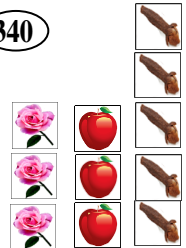

A3B3D5

341

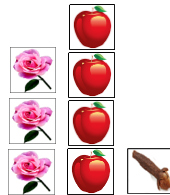

A3B4D1

342

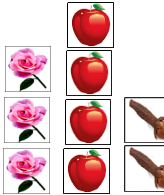

A3B4D2

343

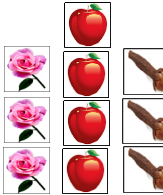

A3B4D3

344

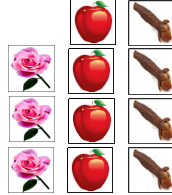

A3B4D4

345

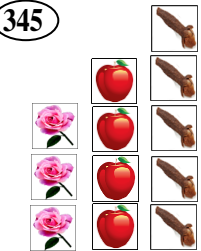

A3B4D5

346

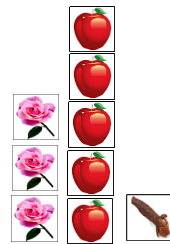

A3B5D1

347

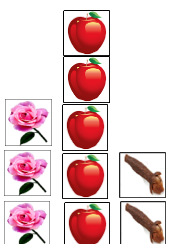

A3B5D2

348

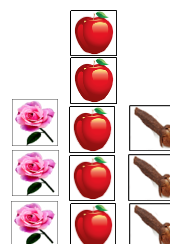

A3B5D3

349

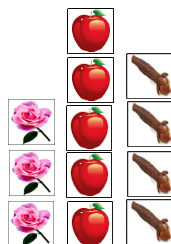

A3B5D4

350

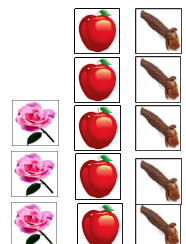

A3B5D5

351

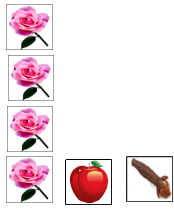

A4B1D1

352

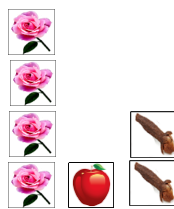

A4B1D2

353

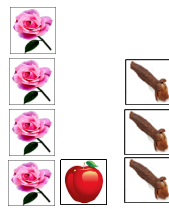

A4B1D3

354

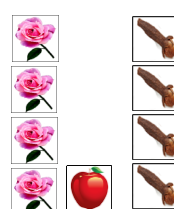

A4B1D4

355

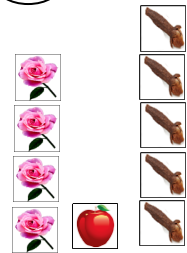

A4B1D5

356

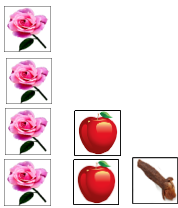

A4B2D1

357

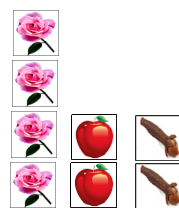

A4B2D2

358

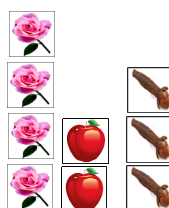

A4B2D3

359

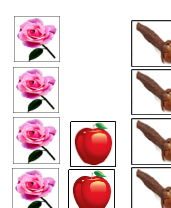

A4B2D4

360

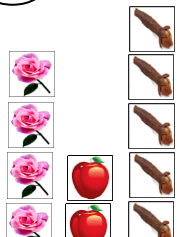

A4B2D5

361

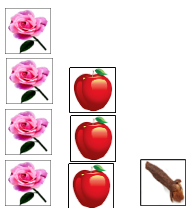

A4B3D1

362

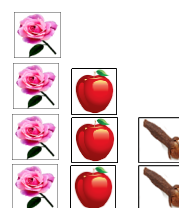

A4B3D2

363

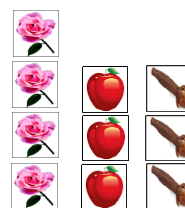

A4B3D3

364

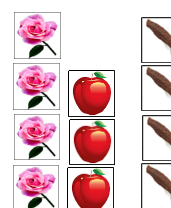

A4B3D4

365

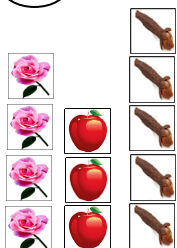

A4B3D5

366

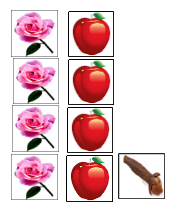

A4B4D1

367

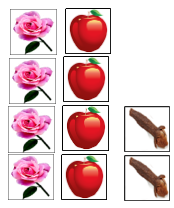

A4B4D2

368

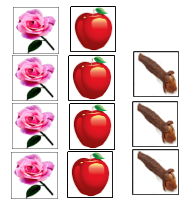

A4B4D3

369

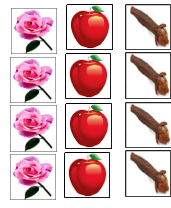

A4B4D4

370

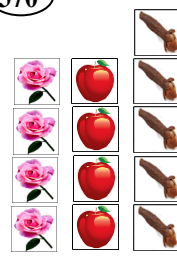

A4B4D5

371

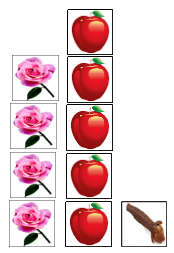

A4B5D1

372

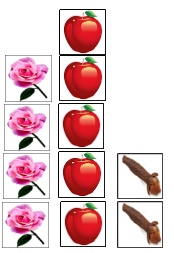

A4B5D2

373

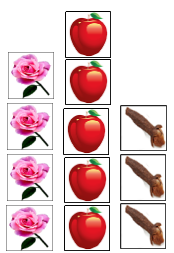

A4B5D3

374

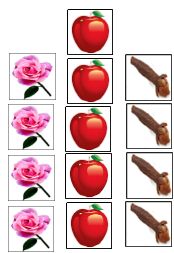

A4B5D4

375

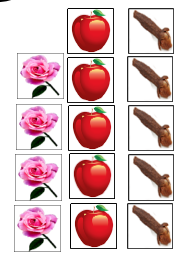

A4B5D5

376

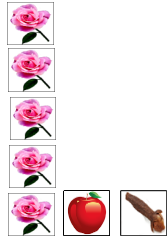

A5B1D1

377

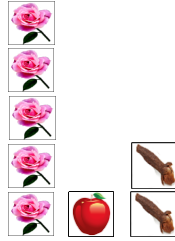

A5B1D2

378

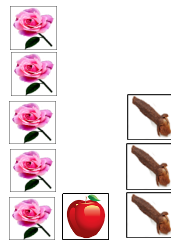

A5B1D3

379

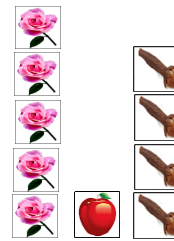

A5B1D4

380

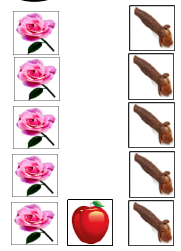

A5B1D5

381

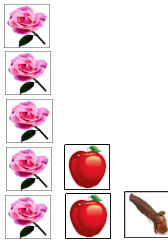

A5B2D1

382

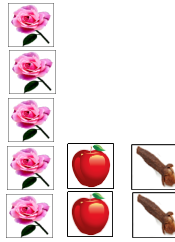

A5B2D2

383

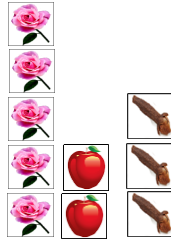

A5B2D3

384

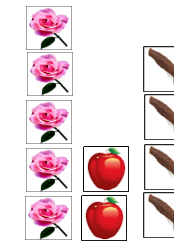

A5B2D4

385

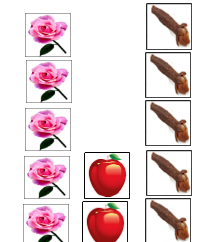

A5B2D5

386

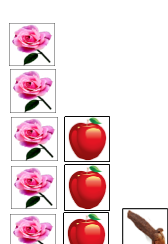

A5B3D1

387

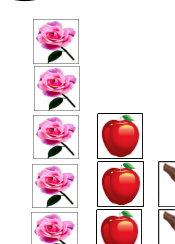

A5B3D2

388

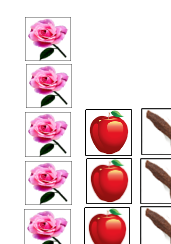

A5B3D3

389

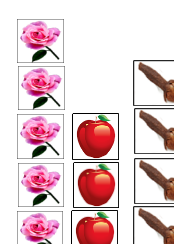

A5B3D4

390

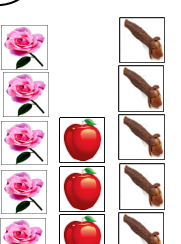

A5B3D5

391

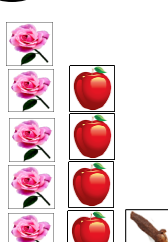

A5B4D1

392

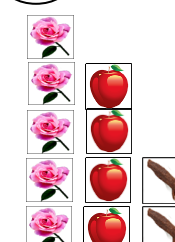

A5B4D2

393

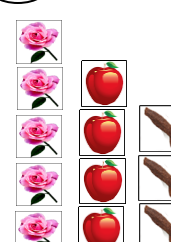

A5B4D3

394

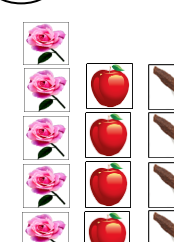

A5B4D4

395

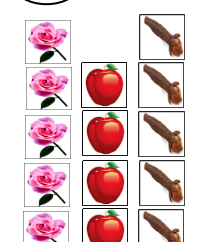

A5B4D5

396

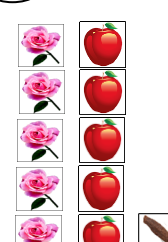

A5B5D1

397

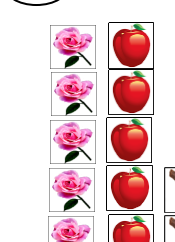

A5B5D2

398

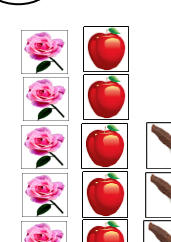

A5B5D3

399

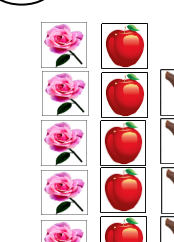

A5B5D4

400

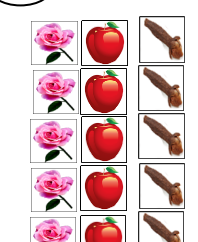

A5B5D5

Accord A,C,D

*أكورد A,C,D

401



A1C1D1

402



A1C1D2

403

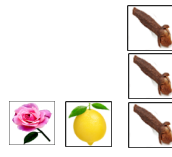

A1C1D3

404

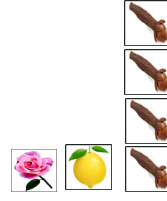

A1C1D4

405

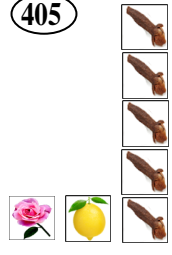

A1C1D5

406



A1C2D1

407



A1C2D2

408

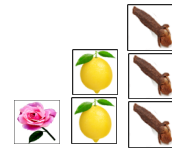

A1C2D3

409

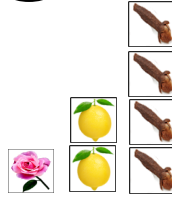

A1C2D4

410

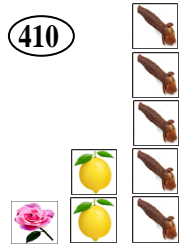

A1C2D5

411

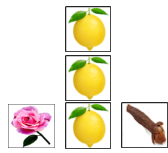

A1C3D1

412

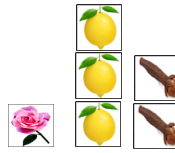

A1C3D2

413

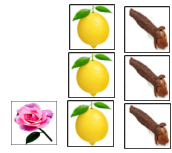

A1C3D3

414

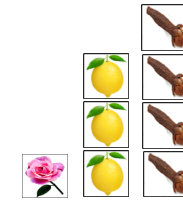

A1C3D4

415

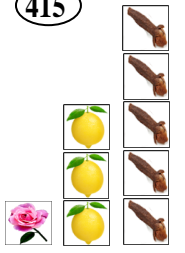

A1C3D5

416

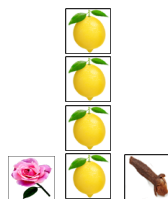

A1C4D1

417

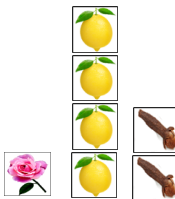

A1C4D2

418



A1C4D3

419

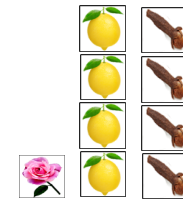

A1C4D4

410

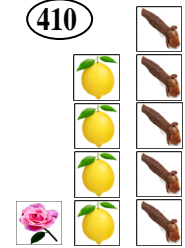

A1C4D5

421



A1C5D1

422



A1C5D2

423

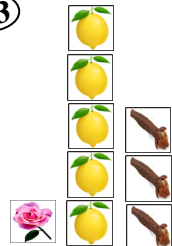

A1C5D3

424

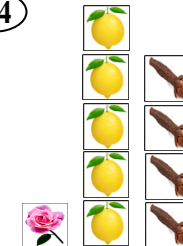

A1C5D4

425

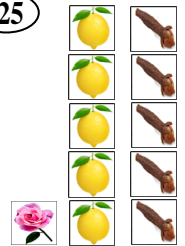

A1C5D5

426



A2C1D1

427



A2C1D2

428

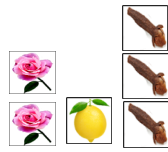

A2C1D3

429

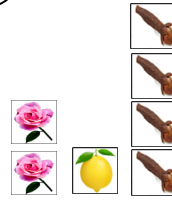

A2C1D4

430

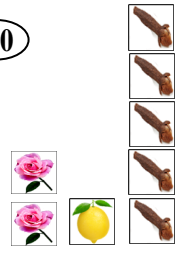

A2C1D5

431



A2C2D1

432

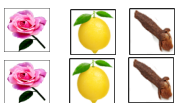

A2C2D2

433

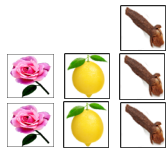

A2C2D3

434

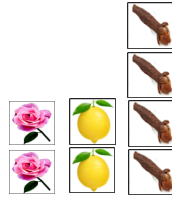

A2C2D4

435

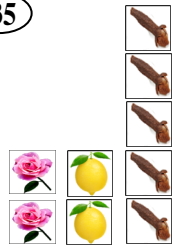

A2C2D5

436

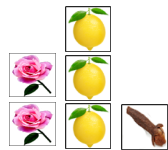

A2C3D1

437

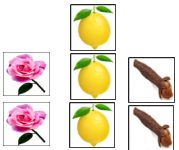

A2C3D2

438

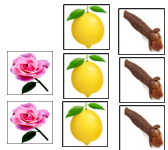

A2C3D3

439

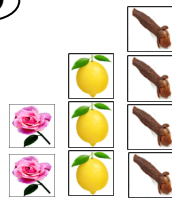

A2C3D4

440

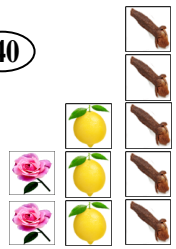

A2C3D5

441

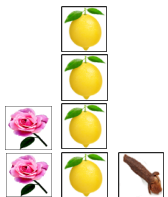

A2C4D1

442

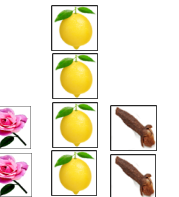

A2C4D2

443

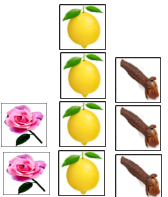

A2C4D3

444

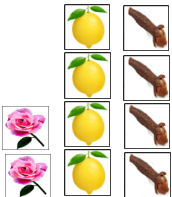

A2C4D4

445

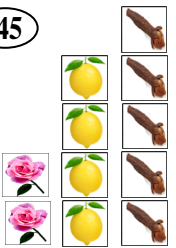

A2C4D5

446

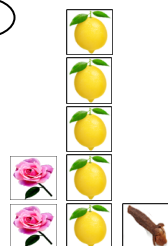

A2C5D1

447

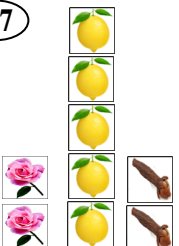

A2C5D2

448

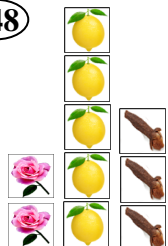

A2C5D3

449



A2C5D4

450

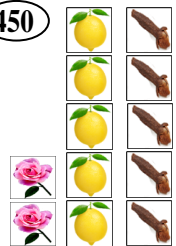

A2C5D5

451

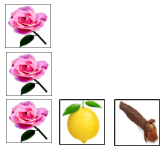

A3C1D1

452

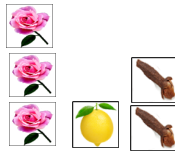

A3C1D2

453

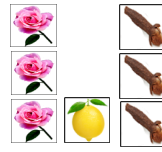

A3C1D3

454

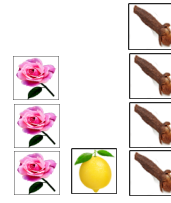

A3C1D4

455

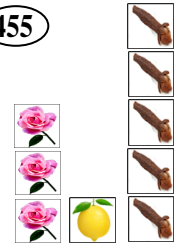

A3C1D5

456

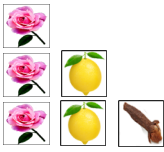

A3C2D1

457

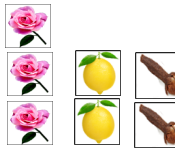

A3C2D2

458

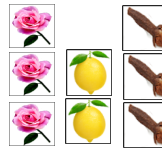

A3C2D3

459

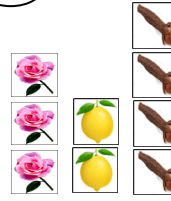

A3C2D4

460

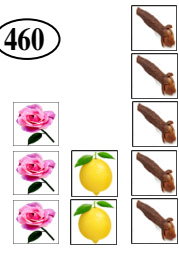

A3C2D5

461

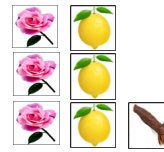

A3C3D1

462

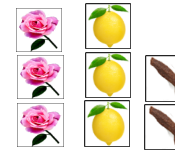

A3C3D2

463

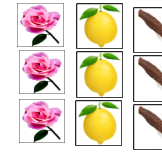

A3C3D3

464

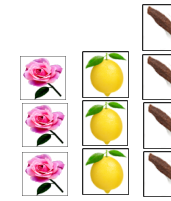

A3C3D4

465

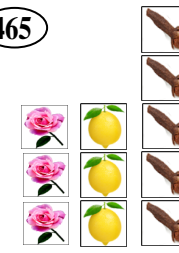

A3C3D5

466

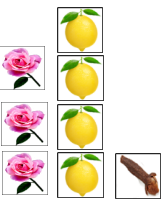

A3C4D1

467

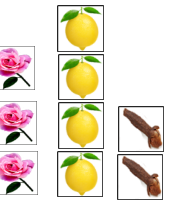

A3C4D2

468

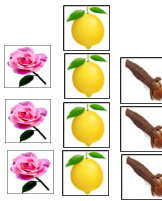

A3C4D3

469

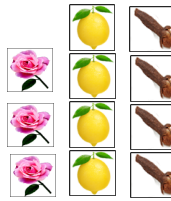

A3C4D4

470

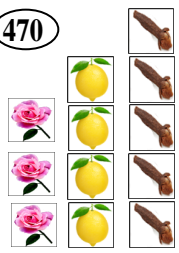

A3C4D5

471

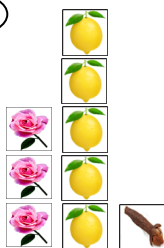

A3C5D1

472

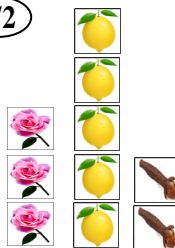

A3C5D2

473

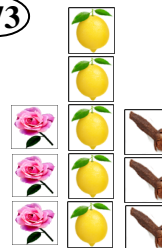

A3C5D3

474

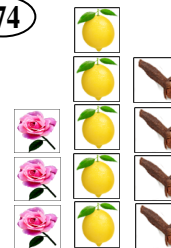





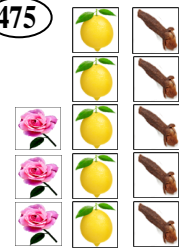

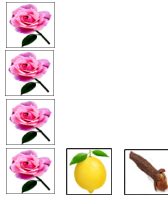
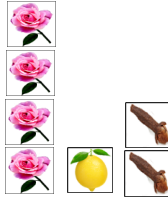
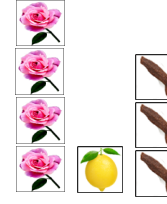
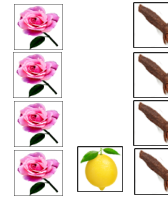
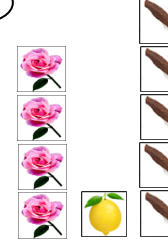
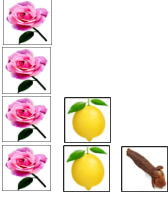
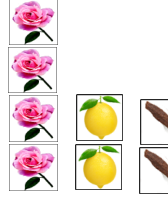
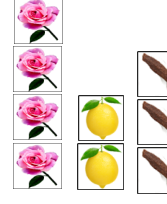
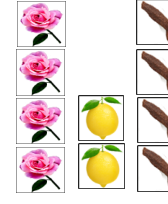
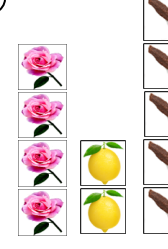
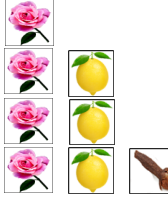
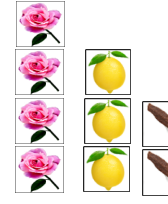
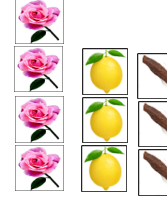
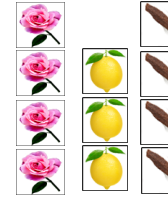

A3C5D4

475

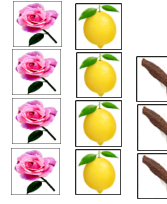
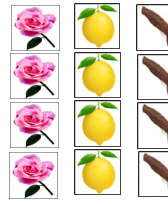

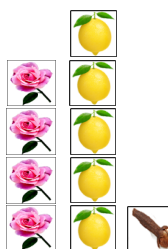
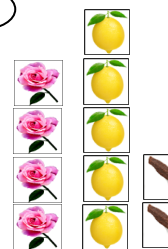
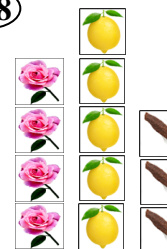
A3C5D5

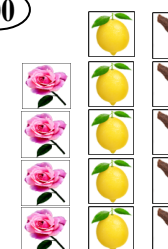
| | | | | |
|---|---|---|--|---|
| (476)  A4C1D1 | (477)  A4C1D2 | (478)  A4C1D3 | (479)  A4C1D4 | (480)  A4C1D5 |
| (481)  A4C2D1 | (482)  A4C2D2 | (483)  A4C2D3 | (484)  A4C2D4 | (485)  A4C2D5 |
| (486)  A4C3D1 | (487)  A4C3D2 | (488)  A4C3D3 | (489)  A4C3D4 | (490)  A4C3D5 |
| (491)  A4C4D1 | (492)  A4C4D2 | (493)  A4C4D3 | (494)  A4C4D4 | (495)  A4C4D5 |
| (496)  A4C5D1 | (497)  A4C5D2 | (498)  A4C5D3 | (499)  A4C5D4 | (500)  A4C5D5 |

501



A5C1D1

502

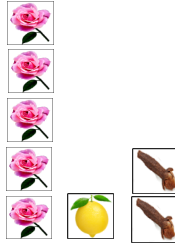

A5C1D2

503

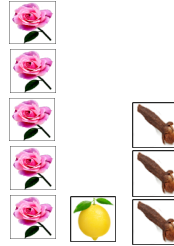

A5C1D3

504

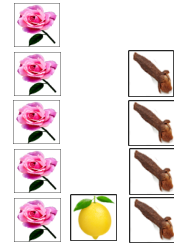

A5C1D4

505

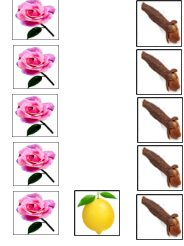

A5C1D5

506

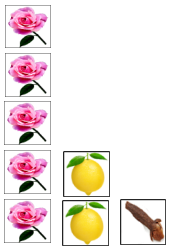

A5C2D1

507

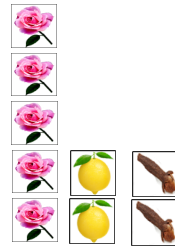

A5C2D2

508

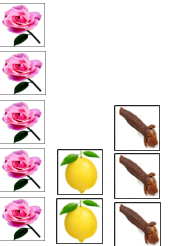

A5C2D3

509

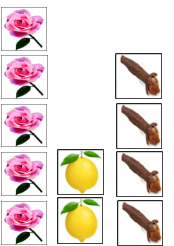

A5C2D4

510

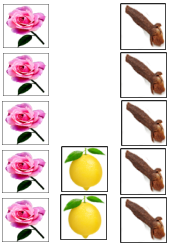

A5C2D5

511

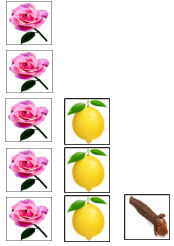

A5C3D1

512

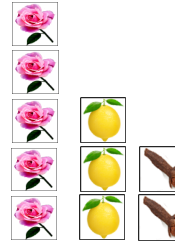

A5C3D2

513

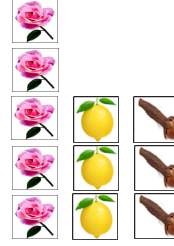

A5C3D3

514

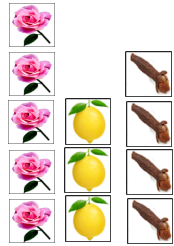

A5C3D4

515

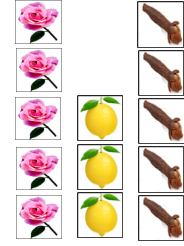

A5C3D5

516

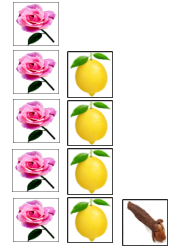

A5C4D1

517

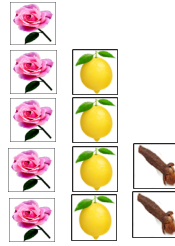

A5C4D2

518

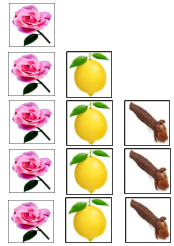

A5C4D3

519

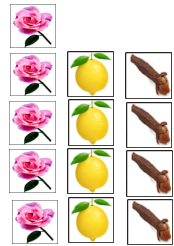

A5C4D4

520

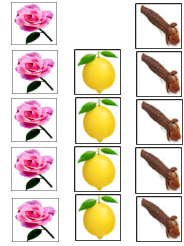

A5C4D5

521

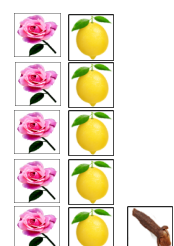

A5C5D1

522

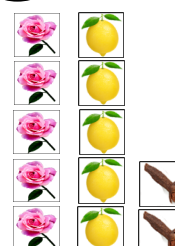

A5C5D2

523

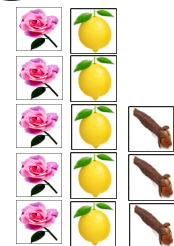

A5C5D3

524

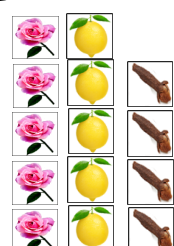

A5C5D4

525

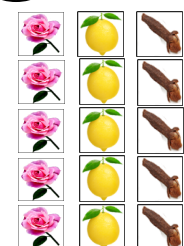

A5C5D5

Accord B,C,D

*أكورد B,C,D

526



B1C1D1

527



B1C1D2

528

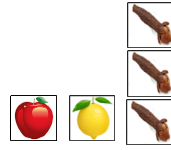

B1C1D3

529

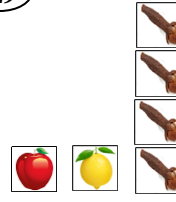

B1C1D4

530

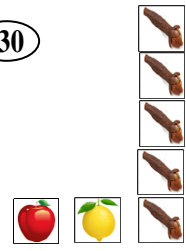

B1C1D5

531



B1C2D1

532



B1C2D2

533

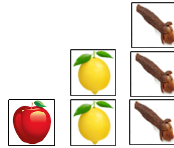

B1C2D3

534

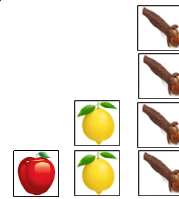

B1C2D4

535

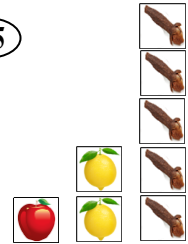

B1C2D5

536

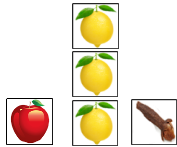

B1C3D1

537

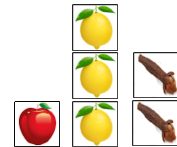

B1C3D2

538

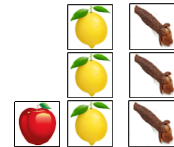

B1C3D3

539

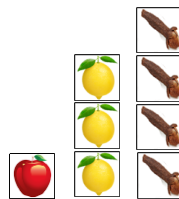

B1C3D4

540

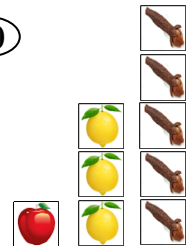

B1C3D5

541

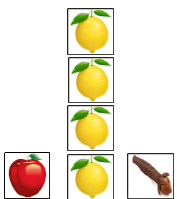

B1C4D1

542

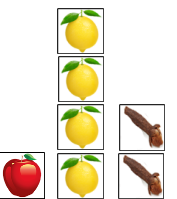

B1C4D2

543

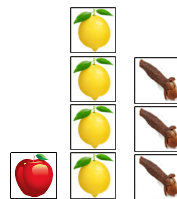

B1C4D3

544

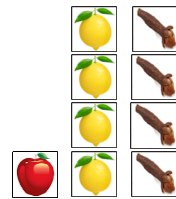

B1C4D4

545

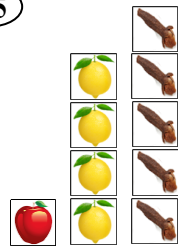

B1C4D5

546

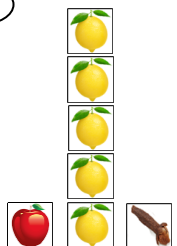

B1C5D1

547

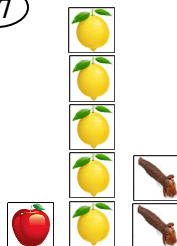

B1C5D2

548

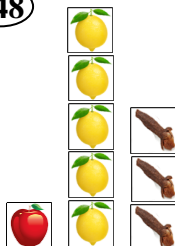

B1C5D3

549

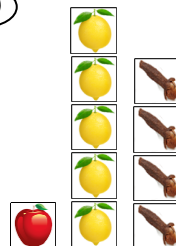

B1C5D4

550

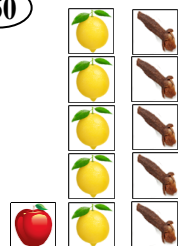

B1C5D5

أخيراً .

كنت أتمنى أن تكون صفحات هذا الكتاب ١٠٠٠ صفحة

حتى يتثنى لي أن أكتب جميع معلوماتي.

أتمنى أن يستفيد جميع مصممي العطور حول العالم من شرحي.

ولمزيد من التوضيح، متابعة قناتي على يوتيوب أو صفحة الفيس بوك أو الويب سايت

إن مصممي العطور هم الأقل عدداً في جميع المهن المختلفة في الحياة لصعوبتها .

اليوم يسهل على الجميع أن يحترف هذه المهنة لإنتاج ملايين خلطات العطور المتميزة.

شكرا لكل من ساهم في إخراج هذا العمل

طارق فراج . مسعد حجازي . محمد عبد الرازق . د/ محمد برهام . على عبد الحليم

تحياتي للجميع

إنتظروا إصداري القادم، (تأثير العطور على النفس والسلوك)

مسعد حسن مسعد النمل

جمهورية مصر العربية

I wished this book had 1000 pages

so I could write down all my knowledge.

I hope that all perfumers around the world benefit from my explanations.

For further clarification, follow my YouTube channel, Facebook page, or website.

Perfumers are among the rarest professionals in the world due to the difficulty of this craft.

Today, anyone can master this profession and create millions of unique fragrance blends.

Thank you to everyone who contributed to the completion of this work:

Tarek Farrag, Mossad Hegazy, Mohamed Abdel Razek, Dr. Mohamed Borham, Ali Abdel Halim.

Best regards to all.

Stay tuned for my next release: "The Effect of Perfumes on the Mind and Behavior"

Mossad Hassan Mossad El-Naml

Arab Republic of Egypt

J'aurais souhaité que ce livre fasse 1000 pages,

afin de pouvoir y écrire toutes mes connaissances.

J'espère que tous les créateurs de parfums dans le monde profiteront de mes explications.

Pour plus de détails, suivez ma chaîne YouTube, ma page Facebook ou mon site web.

Les parfumeurs sont parmi les professionnels les plus rares au monde en raison de la difficulté de ce métier.

Aujourd'hui, il est possible pour chacun de maîtriser cette profession et de créer des millions de mélanges de parfums uniques.

Merci à tous ceux qui ont contribué à la réalisation de ce travail :

Tarek Farrag, Mossad Hegazy, Mohamed Abdel Razek, Dr Mohamed Borham, Ali Abdel Halim.

Mes salutations à tous.

Restez à l'écoute de ma prochaine publication : "L'effet des parfums sur l'esprit et le comportement"

Mossad Hassan Mossad El-Naml

République arabe d'Égypte

فهرس

| | | |
|-----|-------|--|
| 1 | | مقدمة |
| 6 | | العطور .. من أين؟ - وإلى أين؟ قصة العطر |
| 13 | | العائلات العطرية |
| 15 | | المواد الأولية |
| 18 | | قواعد بناء العطر |
| 19 | | نتائج خلط العائلات العطرية قاعدة ال ٦٠ أكورد، جدول-1 |
| 20 | | إعداد ورق الشم |
| 37 | | خلطات العود قاعدة ال ٦٤ أكورد |
| 55 | | خريطة تصميم العطور |
| 56 | | نتائج خلط عائلتين:- أكورد AB |
| 57 | | أكورد AC |
| 58 | | أكورد AD |
| 59 | | أكورد BC |
| 60 | | أكورد BD |
| 61 | | أكورد CD |
| 62 | | نتائج خلط ٣ عائلات:- أكورد ABC |
| 67 | | أكورد ABD |
| 72 | | أكورد ACD |
| 77 | | أكورد BCD |
| 82 | | نتائج خلط ٤ عائلات. أكورد ABCD |
| 107 | | التمثيل البياني للأكوردات |
| 158 | | الخاتمة |

PERFUME DESIGN MAP
CARTE DE CONCEPTION DE PARFUMS

مسعد حسن
MOSSAD HASSAN

خريطة تصميم العطور
PERFUMERS ACADEMY

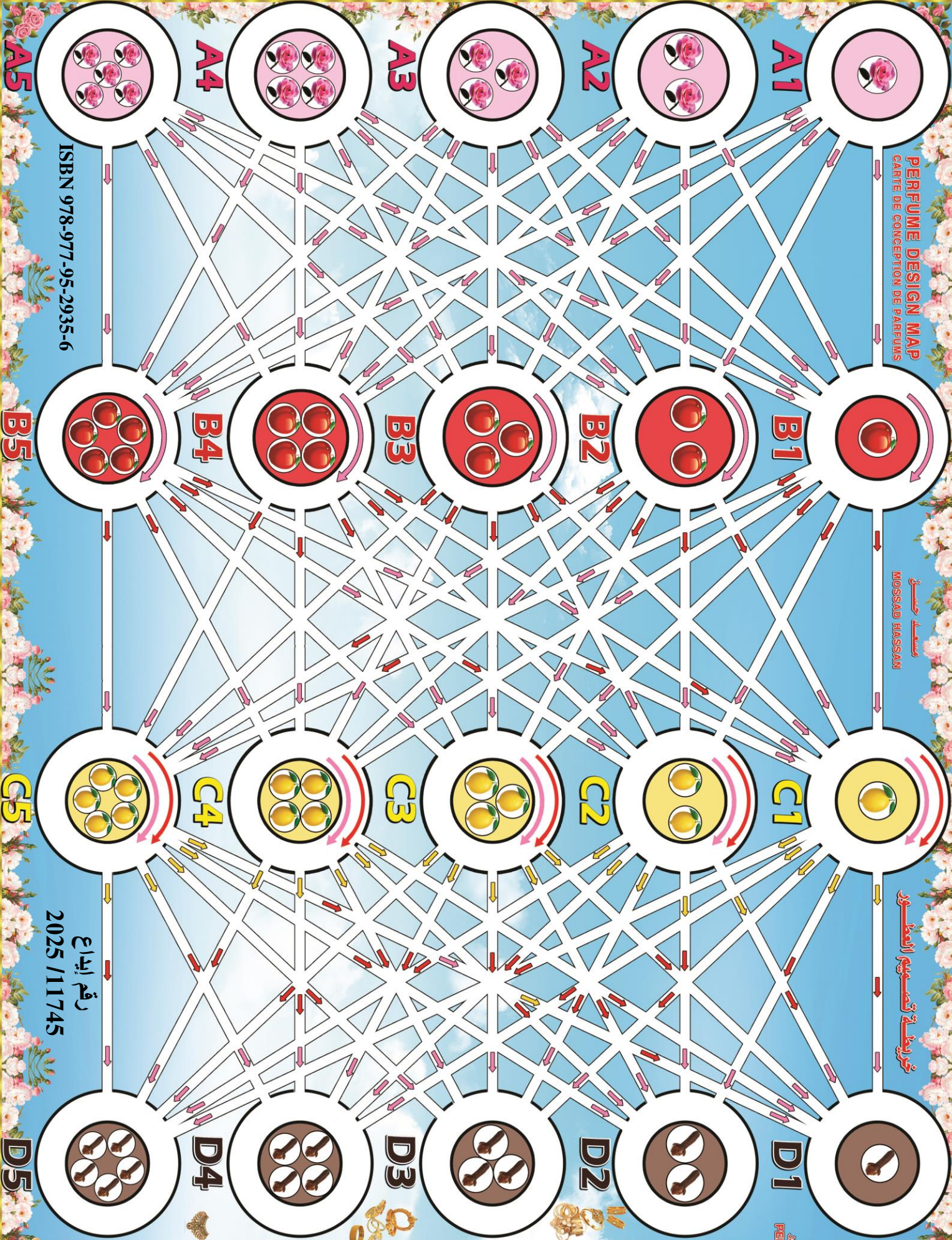

ISBN 978-977-95-2935-6

رقم ايداع
2025 / 11745

D5



خريطة تصميم العطور
PERFUME DESIGN MAP MOSSAD HASSAN
 مسعد حسن





مسعد حسن

- واحد من أهم رواد ومطوري صناعة العطور في مصر والعالم العربي.
- باحث في مجال الزيوت العطرية.
- خبير لدى مصانع إنتاج العطور.
- مصمم عطور وله العديد من التصميمات العطرية.
- صاحب ومؤسس أكاديمية صناع العطور.
- مؤسس العصر الثالث للعطور وفكرة عطور المستقبل ومبتكر خريطة تصميم العطور في العصر الحديث.

Mossad Hassan

- One of the leading pioneers and developers of the perfume industry in Egypt and the Arab world.
- A researcher in the field of essential oils.
- An expert consultant for perfume production factories.
- A perfume designer with numerous fragrance creations.
- Founder and owner of the Perfumers Academy.
- Founder of the Third Era of Perfumes and the concept of Future Fragrances, and the innovator of the modern fragrance design map.

Mossad Hassan

- Lu'n des pionniers et développeurs les plus importants de l'industrie du parfum en Égypte et dans le monde arabe.
- Chercheur dans le domaine des huiles essentielles.
- Expert auprès des usines de production de parfums.
- Créateur de parfums avec de nombreuses compositions olfactives.
- Fondateur et propriétaire de l'Académie des Parfumeurs.
- Fondateur de la Troisième Ère du Parfum et du concept des Parfums du Futur, et inventeur de la carte de conception des parfums à l'ère moderne.